

Description:

The HQ200 and HQ300 electric actuators are specially designed for quarter turn applications such as ball, butterfly, plug valves and dampers. With a wide range of control options the HQ series electric actuator can be configured to meet the demands of any site specification. High quality electrical components, alloy gearing and a high pressure die cast aluminium housing ensure reliability and extended life span.

Standard Specification:

- Enclosure : Weatherproof IP67 (IP68 Option)
- Power Supply : 110/220v 50/60Hz, 380/440V 3Phase
- Duty Cycle (On/Off Duty) : S2, 20 - 50% Max 10 - 30 Min
- Motor : Squirrel Caged Induction Motor
- Limit Switches : 4 x SPDT, 250V AC 10A
- Torque Switches : 2 x SPDT, 250vAC 10A
- Space Heater : 20W(110/220VAC) Anti Condensation
- Conduit Entries : 2 x M25 (PG13.5 OR 1/2"NPT OPTION)
- Travel Angle : 90° ± 5°
- Ambient Temperature : -20°C to +70°C
- External Coating : Anodised before Dry Powder Polyester Coating
- Manual Override : Handwheel with Declutch Mechanism

Option Specification:

- PIU : Potentiometer Unit (1K - 10K)
- PCU : Proportional Control Unit (In/Out: 0-10VDC, 4-20mA)
- CPT : Current Position Transmitter (Output 4-20mA)
- LCU : Local Control Unit (Remote/Open/Stop/Close switch)
- EXA : Explosion Proof Enclosure. ATEX II 2G Eexd IIB T4
- FPA : Fire Proof Actuator. 250°C/150 min

Performance:

MODEL	HQ200	HQ300
TORQUE (Nm)	2000	3000
SPEED 90° 50/60Hz	112/93	112/93
CURRENT (A) MAX	110/1/50	4.10 4.20
	220/1/50	2.30 2.35
	380/3/50	0.85 0.87
WEIGHT (Kg)	75	75
MAX. SQ. DRIVE	55	55

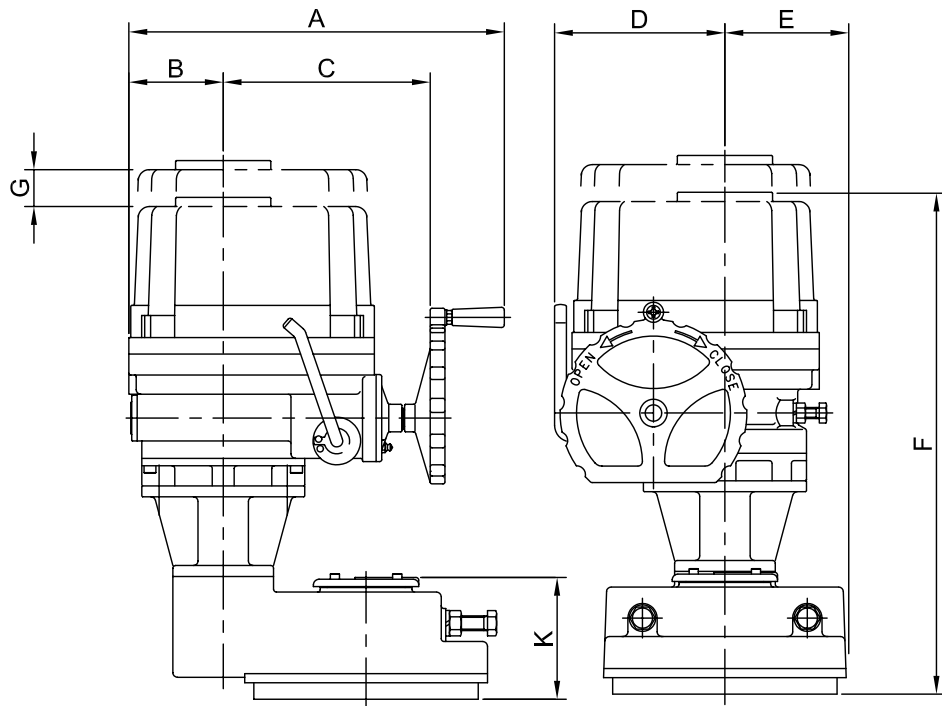
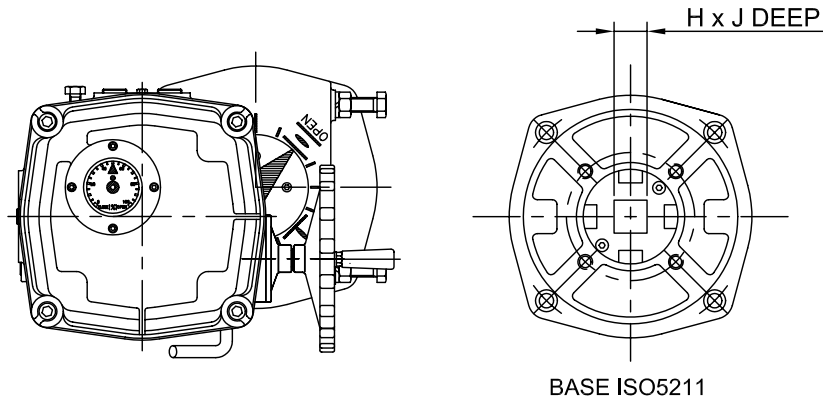

Dimensions:

MODEL	BASE	A	B	C	D	E	F	G	H**	J	K
HQ200	F14*/F16	410	103	242	186	133	563	210	36	95	133
HQ300	F14*/F16	410	103	242	186	133	563	210	46	95	133

* ON REQUEST

** CAN BE MACHINED TO SUIT MOST VALVE STEMS (ON REQUEST)