

Description:

The HQ008 to HQ030 electric actuators with the addition of an integral failsafe battery backup module. The actuators can be configured to fail close or fail open on loss of power. The power pack has sufficient reserve to allow up to five operations within one hour of the power loss. The integral battery module also includes controls for local operation with a padlockable Remote/Local selector, the front panel incorporates LED indicators for the battery charge status and valve close/open position.

Standard Specification:

Enclosure	: Weatherproof IP67 (IP68 Option)
Power Supply	: 110/220V 50/60Hz
Duty Cycle (On/Off Duty)	: S4, 70% Standard, 100% for max 30 mins
Motor	: Squirrel Caged Induction Motor
Limit Switches	: 4 x SPDT, 250V AC 10A
Torque Switches	: 2 x SPDT, 250VAC 10A (HQ015-HQ030)
Space Heater	: 10W(110/220VAC) Anti Condensation
Conduit Entries	: 2 x M25 (PG13.5 OR 1/2"NPT OPTION)
Travel Angle	: 90° ± 5°
Ambient Temperature	: -20°C to +60°C
External Coating	: Anodised before Dry Powder Polyester Coating

Option Specification:

PIU	: Potentiometer Unit (1K - 10K)
PCU	: Proportional Control Unit (In/Out: 0-10VDC,4-20mA)
CPT	: Current Position Transmitter (Output 4-20mA)
FPA	: Fire Proof Actuator. 250°C/150 min

Performance:

MODEL	HQ008	HQ015	HQ020	HQ030
TORQUE (Nm)	80	150	200	300
SPEED 90° 50/60Hz	16/13	25/21	25/21	31/26
CURRENT 110/1/50	1.10	1.65	1.67	1.86
(A) MAX 220/1/50	0.55	0.88	0.89	0.92
WEIGHT (Kg)	15	23	23	28
MAX. SQ. DRIVE	17	19	19	30

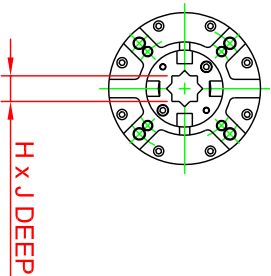
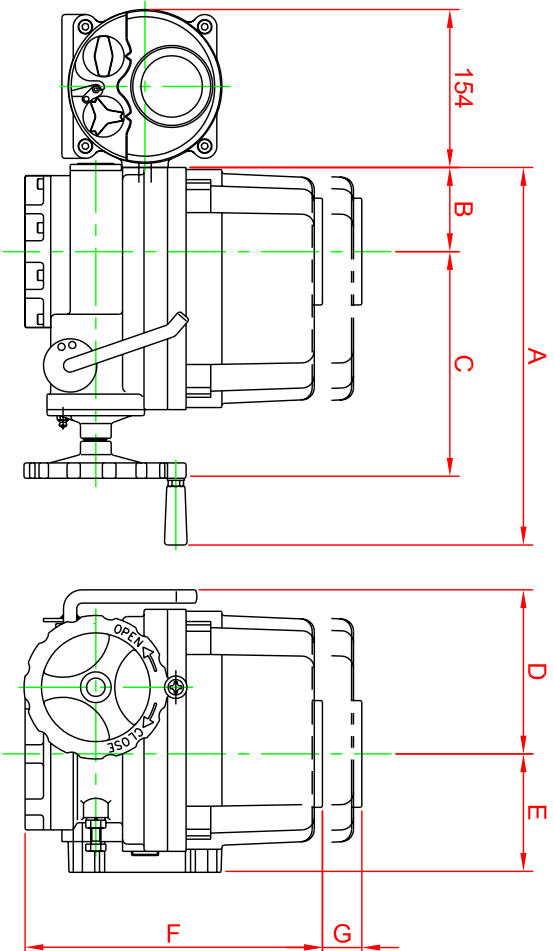

Dimensions:

MODEL	BASE	A	B	C	D	E	F	G	H*	J
HQ008	F07	258	50	157	100	70	235	120	14	35
HQ015	F07/F10	338	73	200	142	87	268	160	17	45
HQ020	F07/F10	338	73	200	142	87	268	160	17	45
HQ030	F10/F12	368	82	221	160	99	290	180	22	52

* CAN BE MACHINED TO SUIT MOST VALVE STEMS (ON REQUEST)