

DOUBLE FLANGED BUTTERFLY VALVE F 012-A



TS-version (through-going shaft)

The double flanged design is suitable for high pressure loading and is excellently suited for use in heavy industry, shipbuilding and waterworks.

TECHNICAL DATA

Nominal diameter:	DN 50 – DN 1200
Face-to-face:	EN 558 Series 13 ISO 5752 Series 13 API 609 Table 2C BS 5155 short NF E 29-305.1
Flange accommodation:	DIN 2501 PN 6/10/16 ANSI B 16.5, Class 150 MSS SP44 Class 150 AWWA C 207 AS 2129 Table D and E BS 10 Table D and E JIS B 2211-5 K JIS B 2212-10 K
Flange Surface Design:	DIN 2526, Form A-E, ANSI RF
Top flange:	EN ISO 5211 NF E 29-402
Marking:	DIN EN 19
Tightness check:	DIN 3230 T3 BO, BN (Leakage Rate 1) ISO 5208, Category 3 API 598 Table 5 ANSI B 16-104, Class VI
Temperature range:	-20 °C to + 160 °C (depending on pressure, medium and material)
Operating pressure:	max. 16 bar
Differential pressure:	max. Δp 16 bar
Vacuum:	0,2 bar absolute (depending on medium and temperature)
Body coating:	Epoxy Resin

FEATURES

- Absolutely tight sealing with flow in either direction
- The valve body and disc are accurately machined which results in low operating torque and long service life and reliability.
- Triple shaft bearings prevents shaft deflection and guarantees optimum guidance even after many years of operating service.
- Can be disassembled, material-specific recycling possible.
- Single flange mounting is possible.
- Can be installed in any desired position.
- Maintenance-free
- Fully repairable valve

GENERAL APPLICATIONS

- Offshore
- Water and wastewater technology
- Shipbuilding

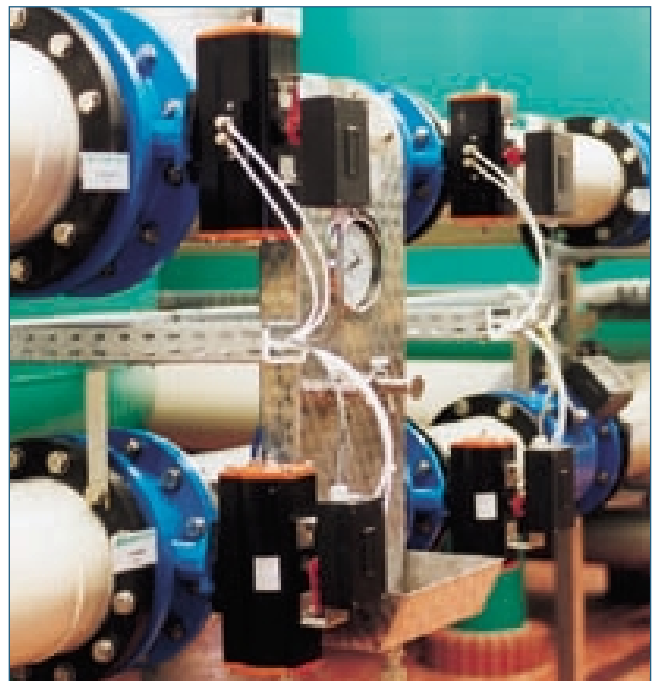

DOUBLE FLANGED BUTTERFLY VALVE F 012-A

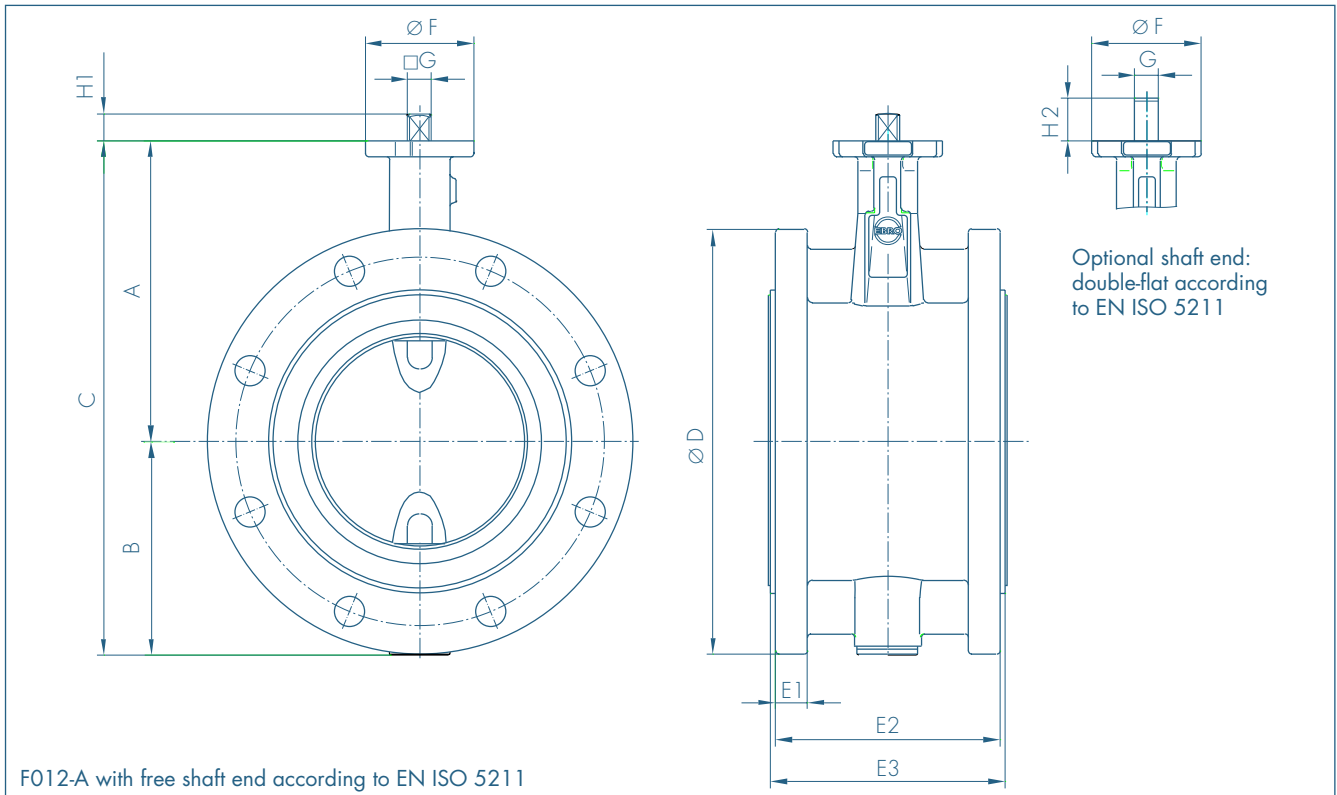

DN [mm]	Size [in]	Dimensions [mm]											Weight [kg]		
		A	B	C	D	E1	E2	E3	F	Flange	G	H1	H2	2 Piece shaft	GGG-40 TS-shaft
50	2	126	84	210	165	15	102	108	54	F04	11	12	19	9,3	-
65	2½	134	93	227	185	15	106	112	54	F04	11	12	19	10,1	-
80	3	157	104	261	200	17	108	114	65	F05	14	16	25	12,2	12,7
100	4	167	115	282	229	17	121	127	65	F05	14	16	25	16,1	16,7
125	5	180	127	307	254	19	134	140	65	F05	14	16	25	24,0	24,6
150	6	203	150	353	285	19	134	140	90	F07	17	19	30	29,0	30,5
200	8	228	176	404	343	21	146	152	90	F07	17	19	30	39,1	40,9
250	10	266	212	478	406	23	159	165	125	F10	22	24	39	61,2	64,2
300	12	291	237	528	483	24	170	178	125	F10	22	24	39	81,4	84,2
350	14	332	269	601	533	24	182	190	150	F12	*	*	-	107,0	112,6
400	16	363	314	677	597	28	208	216	150	F12	*	*	-	142,0	147,8
450	18	397	335	732	640	33	214	222	175	F14	*	*	-	183,0	188,0
500	20	437	405	842	710	40	223	229	210	F16	*	*	-	233,0	240,0
550	22	456	435	891	750	40	219	229	210	F16	*	*	-	268,0	285,0
600	24	502	465	967	840	40	257	267	300	F25	*	*	-	303,0	330,0
700	28	581	507	1088	920	41	286	292	300	F25	*	*	-	407,0	460,0
800	32	630	556	1186	1050	47	312	318	300	F25	*	*	-	604,0	624,0
900	36	696	617	1313	1178	47	320	330	300	F25	*	*	-	745,0	787,0
1000	40	771	675	1446	1280	47	404	410	350	F30	*	*	-	942,0	1090,0
1200	48	905	810	1715	1510	55	460	470	350	F30	*	*	-	-	1400,0

* according to the mounted actuator

Subject to change without notice.

ACTUATORS F 012-A

HAND LEVER

DN [mm]	Size [in]	Hand Lever	F	H	L	Weight [kg]
50-65	2-2 1/2	Size II	54	70	155	0,10
80-125	3-5	Size II	65	80	195	0,15
150-200	6-8	Size III	90	100	276	0,50

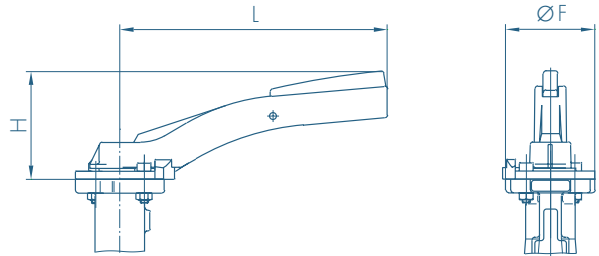

WORM GEAR

DN [mm]	Size [in]	Gear	H	J	K	L	Weight [kg]
50-65	2-2 1/2	Size I	89	39	125	152	1,9
80-125	3-5	Size II	89	39	125	159	1,4
150-200	6-8	Size III	129	47	200	202	2,3
250	10	Size IV	129	60	200	252	2,8
300-350	12-14	Size V	158	76	250	280	6,3
400-450	16-18	Size VI	228	90	356	322	16,0
500	20	Size VII	278	123	457	406	30,5
550-600	22-24	Size VIII	355	154	610	466	45,0
700-800	28-32	Size XIV	295	54	457	466	65,0
900	36	Size XV	294	97	457	498	104,0
1000	40	Size XVI	253	237	356	558	186,0
1200	48	Size XVII	323	292	457	647	262,0

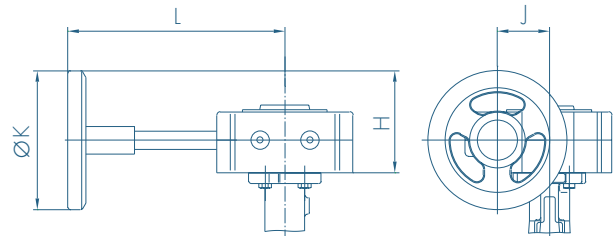

The dimensioning of actuators refers to an operating pressure of 10 bar.

ELECTRIC ACTUATOR

DN [mm]	Size [in]	Actuator Type	H	J/DC	J/AC	K	L	M	Weight [kg]
50-150	2-6	E 60	158	171	171	62	82	110	5,0
200-250	8-10	E 100	183	206	246	74	121	131	11,5
300-350	12-14	E 150	200	238	278	105	189	155	21,0
400-500	16-20	E 200	212	313	313	124	283	220	34,0

The dimensioning of actuators refers to an operating pressure of 10 bar.

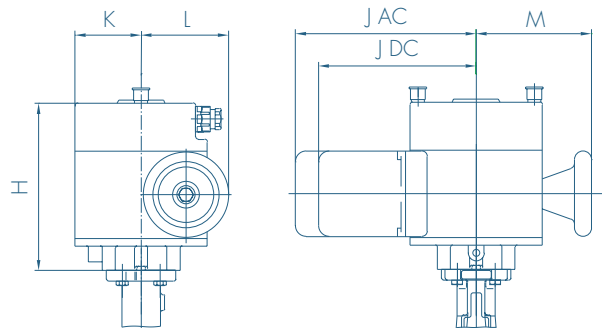

Actuators for larger sizes: See Documentation of the Producer.

Subject to change without notice.

ACTUATORS F 012-A

PNEUMATIC DOUBLE ACTING

DN [mm]	Size [in]	Actuator Type	H	J	K	L	Weight [kg]
50- 65	2-2 ¹ / ₂	EB 4	96	74	49	145	1,1
80-125	3-5	EB 5	108	88	55	174	1,7
150	6	EB 6	123	103	62	208	2,6
200	8	EB 8	136	115	68	250	4,3
250-300	10-12	EB 10	155	135	79	312	6,8
350-400	14-16	EB 265	232	152	76	390	18,0
450	18	EB 270	278	220	110	445	32,0
500-600	20-24	EB 280	278	220	110	600	42,0

The dimensioning of actuators refers to an operating pressure of 10 bar.

Actuators for larger sizes: See Documentation of the Producer.

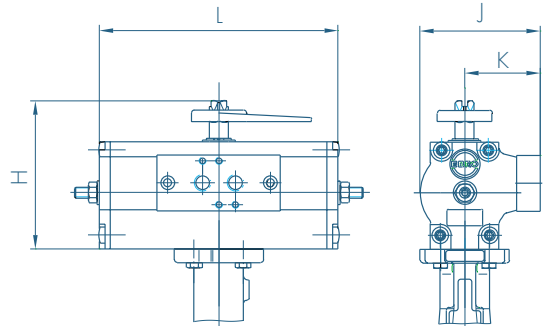

PNEUMATIC SPRING RETURN

DN [mm]	Size [in]	Actuator Type	H	J	K	L	Weight [kg]
50- 65	2-2 ¹ / ₂	EB 5	108	88	55	273	3,0
80-125	3-5	EB 6	123	103	62	326	5,0
150	6	EB 8	136	115	68	389	7,7
200	8	EB 10	155	135	79	526	14,3
250	10	EB 12	182	159	94	656	25,4
300	12	EB 265	232	152	76	634	27,0
350-400	14-16	EB 270	278	220	110	655	45,0
450-500	18-20	EB 280	278	220	110	1020	68,0

The dimensioning of actuators refers to an operating pressure of 10 bar.

Actuators for larger sizes: See Documentation of the Producer.

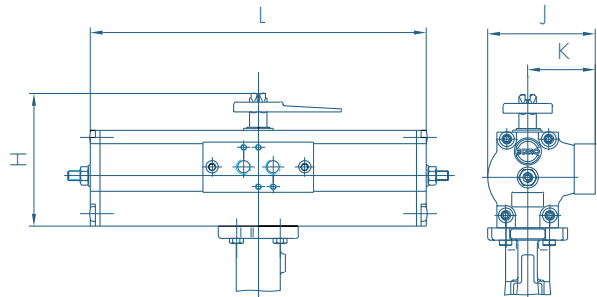

SWITCH BOX SERIES MSK/NSK

MSK: Switch box with integrated micro limit switches.
NSK: Switch box with integrated proximity switches.

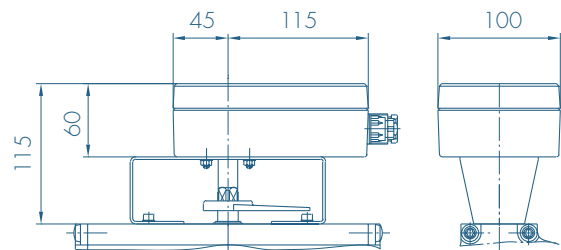

Subject to change without notice.

DOUBLE FLANGED BUTTERFLY VALVE F 012-A

MATERIAL SPECIFICATION AND PARTS LIST

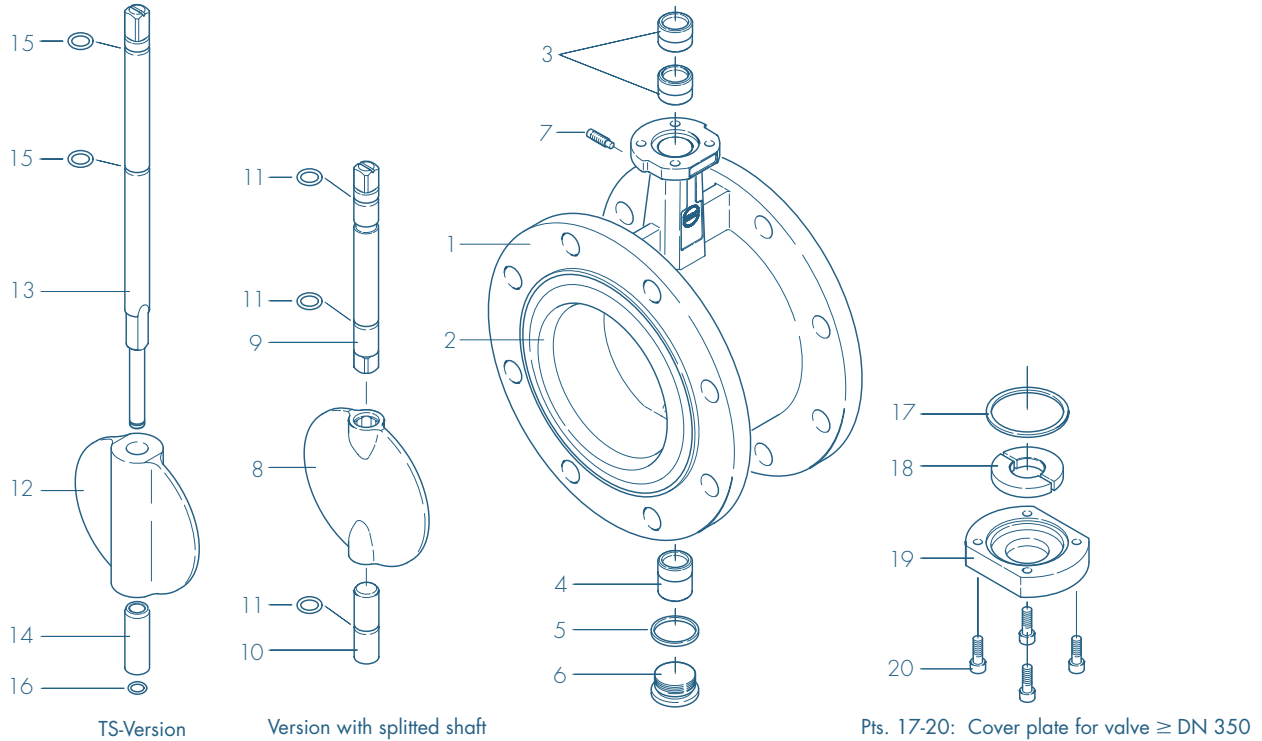

Pt.	Description	Material	Material-No.	ASTM	Pt.	Description	Material	Material-No.	ASTM
1	Body				11	O-ring			
	Nodular Cast Iron	GGG-40	0.7040	60-40-18		NBR	Acrylonitrile butadiene rubber		
2	Seat					FPM	Fluorocarbon caoutchouc		
	NBR	Acrylonitrile butadiene rubber			12	TS-shaft			
	EPDM	Ethylene propylene caoutchouc				Nodular Cast Iron	GGG-40	0.7040	60-40-18
	CSM	Chlorosulphonated polyethylene				Stainless Steel	G-X6CrNiMo10-20	1.4408	CF8M
	FPM	Fluorocarbon caoutchouc				Aluminium Bronze	CuAl10Ni	2.0975	C 95800
	VSI	Silicon rubber				Coating	Halar, Rilsan		
	AU	Polyurethane elastomer				Surface Quality	electropolished, mirror finished		
3/4	Bearing bush				13	TS-shaft			
	Brass	MS58	2.0401	B45		Stainless Steel	X14CrMoS17	1.4104	430F
	Polyamide						X39CrMo17-1	1.4122	
	PTFE						X5CrNiMo17-12-2	1.4401	316
5	Seal DIN 7603				14	Sleeve			
	Copper	Cu		Copper		Stainless Steel	X5CrNi18-10	1.4301	304
6	Plug screw DIN 908				15	O-ring			
	Stainless Steel	11SMnPb30	1.0718 galv.	SAE12L14		NBR	Acrylonitrile butadiene rubber		
	Stainless Steel	G-X5CrNiMo19-11-2	1.4408	CF8M		FPM	Fluorocarbon caoutchouc		
7	Threaded pin DIN 915				16	Retainin ring			
	Steel	45 H galvanized				Stainless Steel	X39CrMo17-1	1.4122	
	Stainless Steel	X5CrNiMo17-12-2	1.4401	B8M	17	O-ring			
8	Disc					NBR	Acrylonitrile butadiene rubber		
	Steel	St52.3 welded	1.0570	572-50	18	Shaft retention			
	Stainless Steel	X5CrNi18-10	1.4301	304		Brass	MS 58	2.0401	B45
		G-X5CrNiMo19-11-2	1.4408	CF8M	19	Cover plate			
		X2CrNiMo17-12-2	1.4404	316l		Grey Cast Iron	GG-25	0.6025	40 B
		X6CrNiMoTi17-12-2	1.4571	316Ti	20	Screw			
		X2CrNiMoN22-5-3	1.4462	F51		Steel	45 H galvanized		
		Hastelloy	2.4883	Hastelloy		Stainless Steel	X5CrNiMo17-12-2		B8M
	Aluminium Bronze	CuAl10Ni	2.0975	C95800					
	Coating	Halar, Rilsan							
	Surface Quality	electropolished, mirror finished							
9/10	Shafts								
	Stainless Steel	X14CrMoS17	1.4104	430F					
		X5CrNiMo17-12-2	1.4401	316					
		Hastelloy	2.4883	Hastelloy					
									Other materials upon request.

Subject to change without notice.

DOUBLE FLANGED BUTTERFLY VALVE F 012-A

TORQUE

- The torque values specified (MD) are based on liquid and lubricant media.
 - Powdery (non-lubricant) media
Md x 1,3
 - Dry gases/high viscous media
Md x 1,2
 - The values specified are based on the initial breakaway torque.
 - Dynamic torque specification available upon request.
- Considering the dimensioning of actuators, please contact our engineers.

DN [mm]	Size [in]	Operating pressure			
		3 [bar]	6 [bar]	10 [bar]	16 [bar]
20	3/4	-	-	5	-
25	1	-	-	5	-
32	1 1/4	-	-	5	-
40	1 1/2	-	-	6	8
50	2	5	7	7	9
65	2 1/2	7	9	15	13
80	3	8	10	18	24
100	4	9	18	28	57
125	5	15	22	45	59
150	6	36	45	110	125
200	8	59	76	140	200
250	10	150	180	200	240
300	12	200	240	280	360
350	14	350	540	610	700
400	16	420	620	750	850
450	18	720	746	860	1500
500	20	900	1100	2255	3690
600	24	1050	1200	3000	5830
700	28	1560	2240	3450	6100
800	32	2070	3800	8600	11 200
900	36	2700	4900	7100	14 500
1000	40	4600	6780	11 500	24 400
1200	48	7800	12 000	21 000	44 000

K_V-VALUES

- The K_V-value (m³per hour) is the flow of water at a temperature of 5 °C to 30 °C (41 °F to 86 °F) at Δp of 1 bar.
 - The K_V-values specified are based on tests carried out by the Delfter Hydraulics Laboratories, the Netherlands.
 - Permissible velocity of flow
V_{max} 4,5 m/s for liquids and
V_{max} 70 m/s for gases.
 - The throttle function is linear at an angle 30° to 70°.
 - Avoid cavitation!
- For further values, please contact our engineers.

DN [mm]	Size [in]	Opening angle α°							
		20°	30°	40°	50°	60°	70°	80°	90°
20	3/4	-	1	4	8	11	19	27	32
25	1	-	1,5	5	10	15	24	32	36
32	1 1/4	-	1,5	5	11	16	27	35	40
40	1 1/2	-	2,2	8	15	21	33	43	50
50	2	1,2	8	13	22	38	50	65	85
65	2 1/2	2	9	22	42	77	115	170	215
80	3	8	24	50	95	150	240	330	420
100	4	13	28	65	130	180	340	550	800
125	5	26	65	130	230	350	530	870	1010
150	6	35	90	200	360	640	900	1350	2100
200	8	43	180	350	580	1000	1600	3000	4000
250	10	125	360	660	1100	1800	3100	5300	6400
300	12	200	550	1000	1600	2600	5000	7500	8500
350	14	350	780	1400	2400	4000	8000	10 800	11 500
400	16	490	1050	1800	3100	5500	11 000	12 000	14 500
450	18	510	1080	2040	3350	6100	11 500	14 600	20 500
500	20	520	1100	2200	3500	6200	12 000	15 100	21 000
600	24	750	1400	2800	5100	8800	14 000	22 000	29 300
700	28	770	1755	3260	5980	10 600	17 100	25 300	36 000
800	32	1200	2260	4550	8230	12 900	20 300	29 300	44 600
900	36	1540	2280	6030	10 500	17 600	29 200	42 150	59 000
1000	40	2200	3970	8300	14 480	24 000	37 100	60 300	81 500
1200	48	5050	7900	13 800	19 700	33 500	53 300	73 050	102 650