

DIMENSIONS AND TECHNICAL DETAILS

HQ008 + PCU

Description :

The HQ-008 electric actuators are specially designed for quarter turn applications such as small ball, butterfly, plug valves and dampers.

Small, light and compact design with high output torques.

This variation is fitted with a proportional control unit (PCU) providing modulating control from an incoming signal.

The combination of electronic positioner, position transmitter and microprocessor technology provides extremely high reliability and performance.

An auto calibration feature provides the user with easy set up and installation by pressing one button.

Standard Specification :

Enclosure	:	Weatherproof IP67
Power Supply	:	110/220v 50/60Hz
Duty Cycle (Modulating)	:	S4 30-50%
Motor	:	Reversible Motor
Limit Switches	:	2 x SPDT, 250V AC 10A
Space Heater	:	20W (110/220V AC)
Manual Override	:	Detachable
Conduit Entries	:	2 x M25
Ambient Temperature	:	-20°C to +70°C
External Coating	:	Dry Powder, Polyester
Input Signal	:	4-20mA, 0-20mA, 0-10VDC, 1-5VDC
Output Signal	:	4-20mA, 0-10VDC
Adjustable Range	:	Zero 8mA, Open 16mA
Input Resistance	:	250 ohm, Feedback Signal: 1k-10k ohm
Load Resistance	:	Max 750 ohm
Resolution	:	Min 1/1000

Performance

TYPE (MODEL)	MAXIMUM OUTPUT TORQUE	OPERATING TIME 50/60Hz	MOTOR CLASS F FRAME SIZE	RATED CURRENT (A)		WEIGHT
				W * F		
HQ-008	80Nm	16/13 SECS	15 * 70	0.95/1.10	0.54/0.55	7.4
		90°		110V	220V	Kg

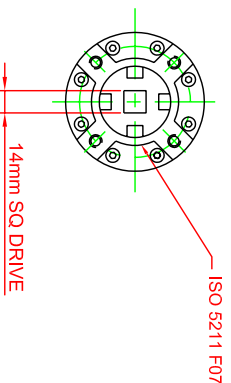
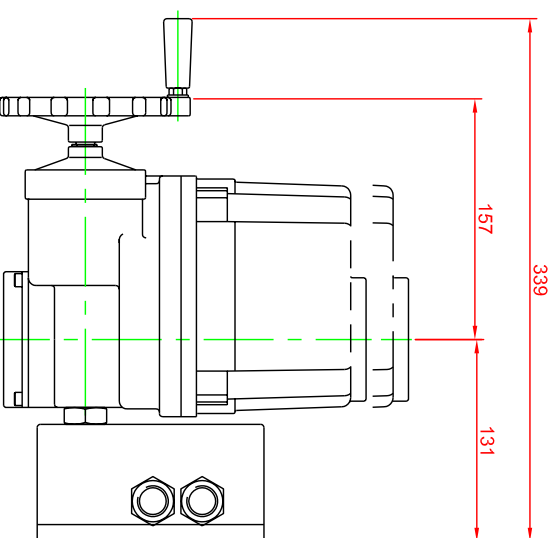
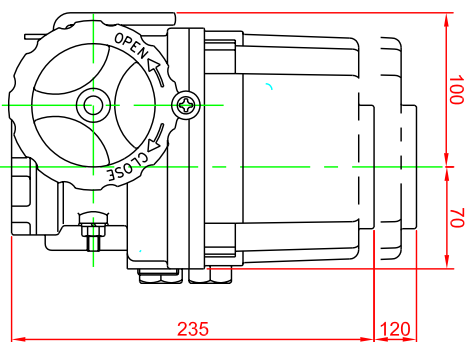
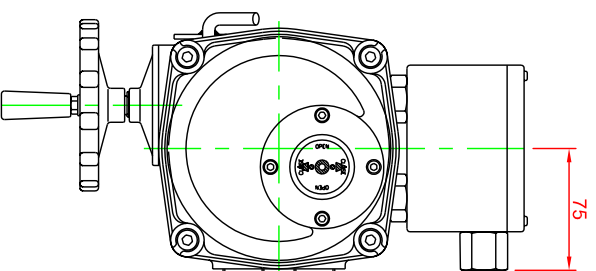

DATA SHEET No.	3.12
ISSUE DATE	DEC 2005
ISSUE REF	A