

HIGH PERFORMANCE BUTTERFLY VALVE HP 114

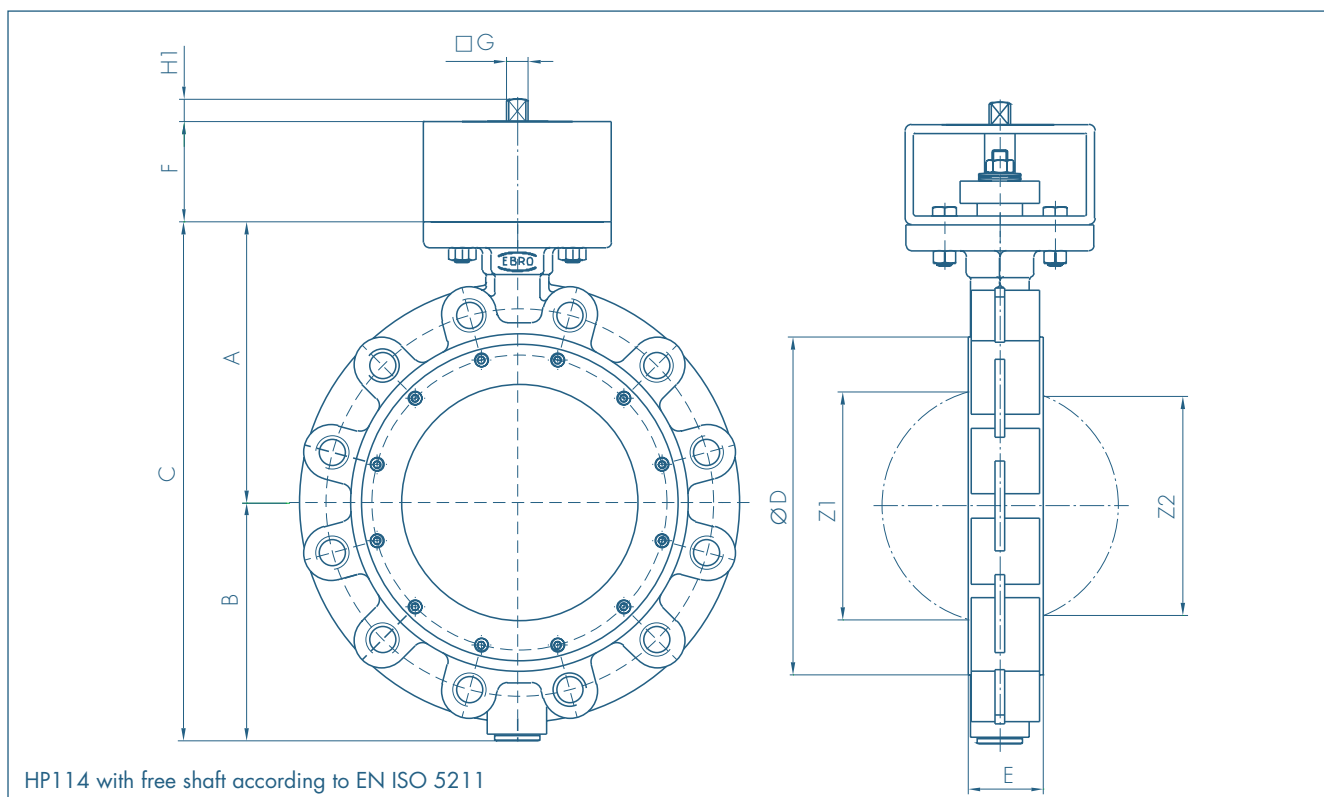

DN [mm]	Size [in]	Dimensions [mm]											min. Pipe-Ø	Weight [kg]
		A	B	C	D	E	F	Flange	G	H1	Z1	Z2		
50	2	133	93	226	112	43	80	F05	12	15	40,9	-	51	7,4
65	2½	133	93	226	112	43	80	F05	12	15	40,9	-	51	7,4
80	3	142	107	249	138	46	80	F05	12	15	70,7	54,4	80	10,2
100	4	158	118	276	160	52	80	F05	12	15	94,2	81,6	103	13,5
125	5	181	134	315	192	56	80	F07	14	18	114,5	105,3	124	17,6
150	6	195	148	343	216	56	80	F07	14	18	143,5	135,4	151	21,0
200	8	225	185	410	270	60	80	F10	17	18	187,4	181,2	196	32,9
250	10	268	215	483	326	68	80	F12	22	23	235,2	228,8	245	49,0
300	12	300	248	548	378	78	90	F12	27	28	280,7	275,8	296	68,5
350	14	345	304	649	438	92	100	F14	27	28	322,8	315,9	334	104,0
400	16	375	339	714	488	102	100	F14	36	36	371,6	363,9	385	135,0
450	18	412	340	752	530	114	120	F16	36	36	426,8	426,8	438	174,0
500	20	425	399	824	593	127	120	F16	46	46	468,7	466	484	240,0
550	22	456	405	861	635	154	200	F25	46	46	525,7	525,7	540	268,0
600	24	490	468	958	692	154	200	F25	55	55	544,5	542,2	560	390,0

Subject to change without notice.

HIGH PERFORMANCE BUTTERFLY VALVE HP 114

MATERIAL SPECIFICATION AND PARTS LIST

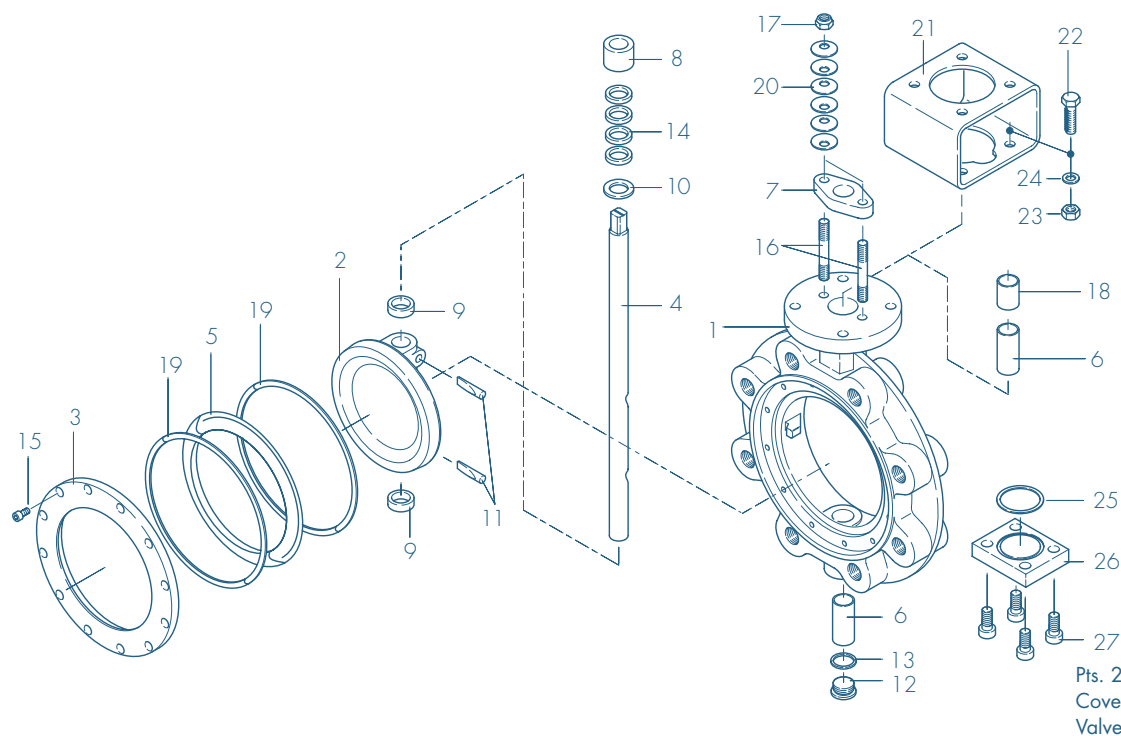

Pt.	Description	Material	Material-No.	ASTM	Pt.	Description	Material	Material-No.	ASTM		
1	Body	Carbon Steel	GS-C25N	1.0619	WCB	14	Shaft seal				
		Stainless Steel	G-X5CrNiMo19-11-2	1.4408	CF8M			PTFE			
2	Disc										
		Stainless Steel	G-X5CrNiMo19-11-2	1.4408	CF8M	15	Hex.-socket screw	Stainless Steel	A4-70	B8M	
3	Clamping	Steel	St37-2	1.0037	283-C	16	Threaded pin	Stainless Steel	A2-70	B8M	
		Stainless Steel	X5CrNiMo17-12-2	1.4401	316			17	Hex. nut	Stainless Steel	A2
4	Shaft					18	Spacer sleeve	Stainless Steel	X6CrNiMoTi17-12-2	1.4571	316 Ti
		Stainless Steel	X4CrNiMo16-5	1.4418				19	Graphite seal (for metal seat)	Graphite	
5	Seat ring	R-PTFE	PTFE-Compound			20	Belleville sp. washer	Spring Steel	50CrV4	1.8159	6150
		Inconel	Inconel 625					Stainless Steel	X6CrNiMoTi17-12-2	1.4571	316 Ti
6	Shaft bearing					21	Bracket	Steel	St32-2 galvanized	1.0037	283-C
		Stainless Steel	X5CrNiMo17-12-2	1.4401/PTFE	316 PTFE			22	Hex. bolt	Steel	St galvanized
7	Gland flange					23	Hex. nut	Steel	St galvanized	CS	
		Stainless Steel	X5CrNi18-10	1.4301	304			24	Washer	Steel	St galvanized
8	Thrust collar					25	Seal	Graphite			
		Stainless Steel	X5CrNi18-10	1.4301	304			26	Coverplate	Steel	St 37-2 galvanized
9	Bearing ring					27	Hex.-socket screw	Stainless Steel	A2-70	B 8	
		Stainless Steel	X6CrNiMoTi17-12-2	1.4571chr-pld	316 Ti						
10	Suppor. washer										
		Stainless Steel	X6CrNiMoTi17-12-2	1.4571	316 Ti						
11	Taper pin										
		Stainless Steel	X4CrNiMo16-5	1.4418							
12	Plug screw DIN 908	Machining Steel	11SMnPb30	1.0718	ni-pld	SAE 12L14					
		Stainless Steel	G-X5CrNiMo19-11-2	1.4408	CF8M						
13	Seal	PTFE									
		Graphite									Other materials upon request

Pts. 25-27:
Cover plate for
Valve \geq DN 350

HIGH-PERFORMANCE BUTTERFLY VALVE HP 114

Torque

- The values specified are based on the initial breakaway torque. (disc disengages from seat, torque than drops).

DN [mm]	Size [in]	Operating Pressure							
		10 [bar]		16 [bar]		25 [bar]		40 [bar]	
		R-PTFE	Inconel	R-PTFE	Inconel	R-PTFE	Inconel	R-PTFE	Inconel
50-65	2-2½	27	35	28	42	30	58	31	66
80	3	28	55	30	65	34	90	38	100
100	4	51	90	61	100	80	120	93	140
125	5	63	150	83	172	95	220	125	285
150	6	125	170	136	220	168	300	220	360
200	8	205	350	260	430	280	505	*	*
250	10	485	505	550	620	600	860	-	-
300	12	584	740	700	970	855	1280	-	-
350	14	740	815	930	1050	1200	1370	-	-
400	16	1150	1530	1640	2240	2460	2900	-	-
450	18	1150	1700	1750	2500	2700	3500	-	-
500	20	1210	2010	1800	2760	2800	4260	-	-
550	22	3500	3750	4430	4550	6010	6800	-	-
600	24	4000	4500	4600	5740	6200	8080	-	-

All Values in Nm

PRESSURE-/TEMPERATURE DIAGRAM

----- Pressure control line for GS-C25 body material and metal seat

————— Pressure control line for 1.4408 body material and metal seat

- · - · - · Pressure control line for R-PTFE-seat

The diagram illustrates the performance of the standard version of valve type HP 114. Valves for higher pressure or deviating temperature are available upon request.

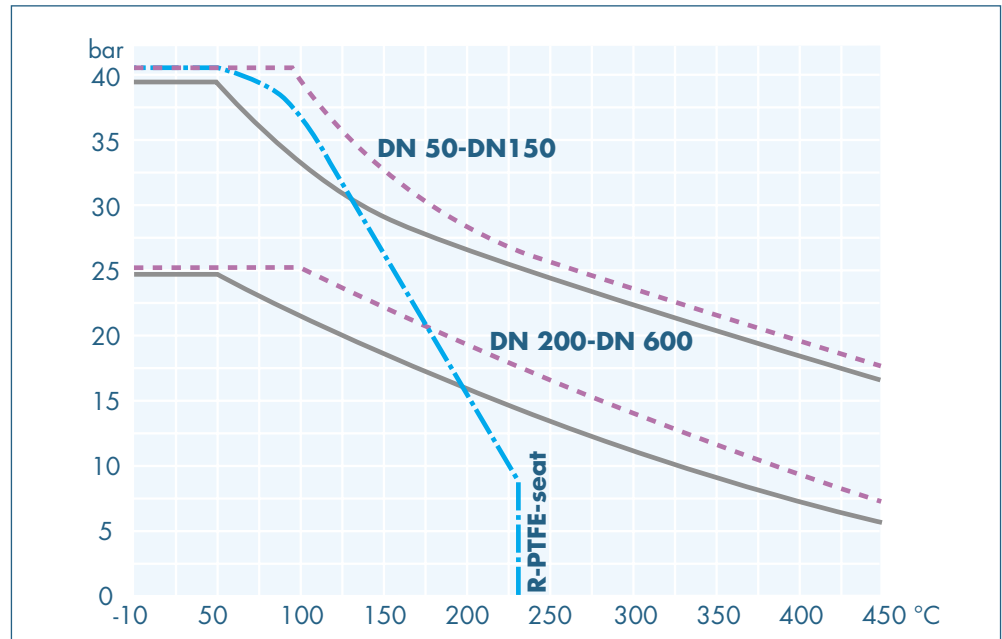

K_v-VALUES

- The K_v-value (m³ per hour) is the flow of water at a temperature of 5 °C to 30 °C (41 °F to 86 °F) Δp of 1 bar.

- The K_v-values specified are based on tests carried out by the Delft Hydraulics Laboratories, the Netherlands.

DN [mm]	Size [in]	Opening angle							
		20°	30°	40°	50°	60°	70°	80°	90°
50	2	5	23	38	56	67	81	101	109
65	2½	5	23	38	56	67	81	101	109
80	3	7	30	50	68	82	97	113	115
100	4	22	60	97	119	164	199	223	251
125	5	45	100	152	195	256	346	452	493
150	6	63	109	162	250	391	588	814	845
200	8	96	168	301	509	742	1107	1581	1747
250	10	264	458	682	980	1421	2083	2882	2889
300	12	397	625	956	1368	1938	2778	3794	3940
350	14	460	720	1100	1650	2500	3400	4800	5400
400	16	550	870	1250	2000	3200	4800	6800	8080
450	18	730	1200	1800	3100	4600	6400	8400	10500
500	20	920	1600	2600	4100	6000	8500	12100	12800
550	22	1090	1950	3100	4600	7500	10200	14700	15300
600	24	1370	2250	3780	4950	9000	12500	17100	18500

Subject to change without notice.

Cambrian Valves Ltd
www.cambrianvalves.co.uk

11.2001 PDF