

# MAX-AIR SCOTCH YOKE ACTUATORS

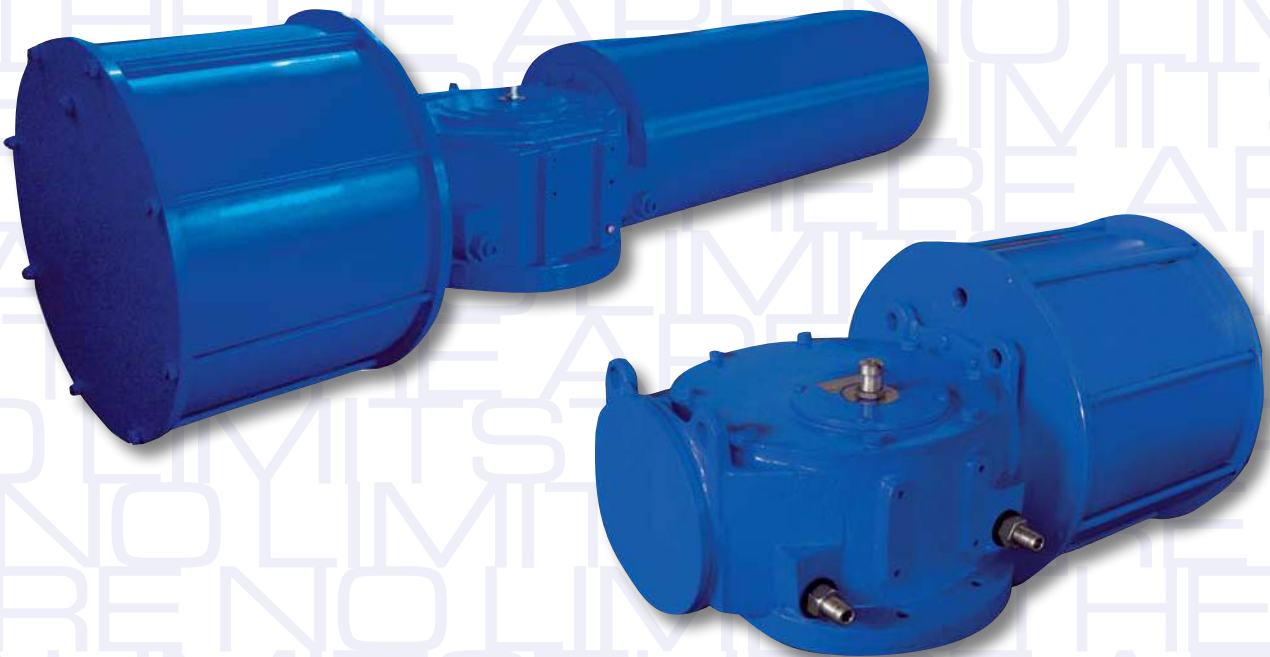

SY SERIES SCOTCH YOKE ACTUATORS



## FEATURES

### MODULAR DESIGN

The Max-Air SY series scotch yoke actuator has a highly efficient and interchangeable modular design (air cylinder, power drive, spring pack, and override module) providing for easy field modification and serviceability.

### NAMUR MOUNTING

NAMUR VDI/VDE 3845 dimensional standard on all sizes. No special blocks or hardware required to mount solenoid valves, limit switches, or positioners.

### DEGREE OF TRAVEL

Each SY actuator has been engineered with bidirectional travel stops which allow for total travel adjustment between 80° and 100°.

### ISO MOUNTING

Designed in accordance to the ISO 5211 dimensional and torque range specification for easy and cost effective automated valve assemblies.

### HIGH CYCLE BEARINGS

All critical-to-operation bearings have been designed with self-lubrication allowing for maximum energy transfer directly to the valve stem. The pre-compressed spring pack minimizes radial loads on the piston rod and increases the service life and durability of the actuator. Replaceable bearings protect all sliding and rotating components for maximum life.

### SELF-LUBRICATING

All SY series actuators have been designed to be completely self-lubricating, requiring no further lubrication, ensuring maximum wear resistance and long cycle life.

### QUALITY ASSURANCE

100% of all units are factory pressure tested, no-leak verified, and torque performance guaranteed prior to shipment.

### WATERTIGHT DESIGN

O-rings are sized to exact specifications creating a watertight design.

### SAFETY LOCK

Each SY series actuator has been engineered with safety as its highest priority. The SY series actuator features a specially designed safety lock mechanism so that the spring module can only be removed from the power module when the spring is fully decompressed. This important safety feature prevents accidental release of spring tension. The spring lock mechanism safely retains the spring module under load, and prevents the module from being removed when the actuator is under load conditions.

### INTEGRAL CHECK VALVE

An integral check valve is incorporated into the design of the SY series actuator to prevent over pressurizing and foreign material from getting inside the unit. This prevents premature break down and increases the life of the actuator.

### POWER YOKE DESIGN

Each scotch yoke power mechanism has been precisely machined to exact tolerances and fitted with high quality, self-lubricating bearings, piston rod, and guide block for high efficiency energy transmission, smooth operation, and trouble-free service.

### HYDRAULIC OVERRIDE

The SY series offers a hydraulic override cylinder module on all spring return models. This important feature does not increase the overall length of the body.

### CORROSION RESISTANCE

Each unit comes standard with a minimum of three progressive stages of internal and external coating for corrosion resistance. The inner lining of the cylinder wall is coated with infused PTFE, thereby enhancing internal corrosion resistance and self-lubrication.

### HANDLING

The SY series actuators come with easy to handle eye bolts which make for ease of lifting and transporting. Please call for further details.

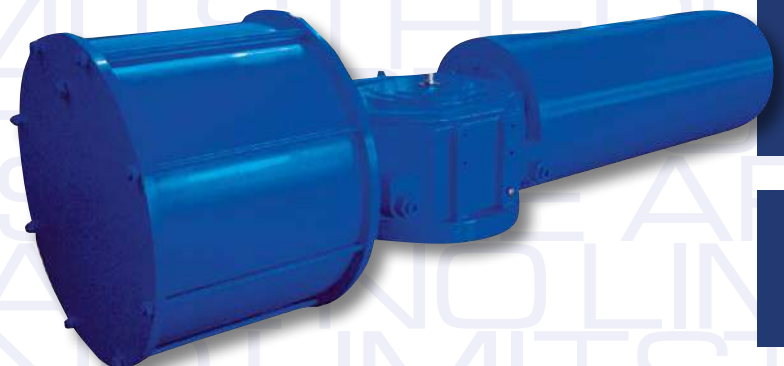
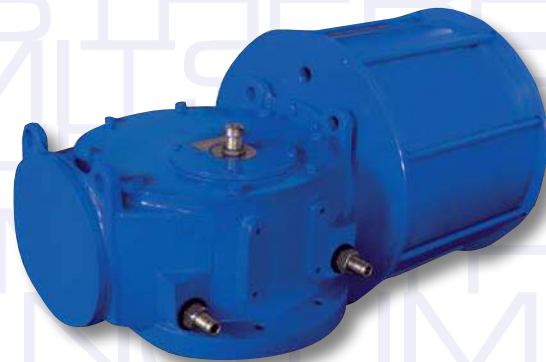

# DRAWING & PARTS LIST

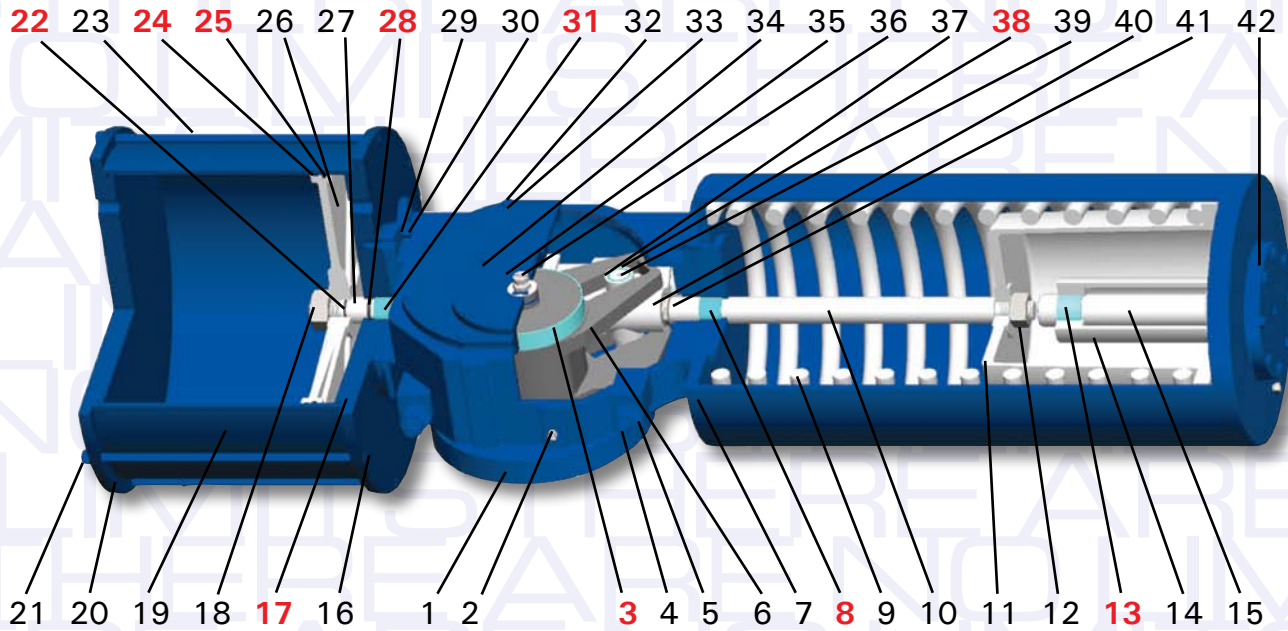

Item	Description	Materials	Item	Description	Materials
1	Body	Ductile Iron	22	Rod BUNA-N O-Ring Seals	BUNA-N
2	Vent Valve	WCB	23	Screw	Steel Alloy
3	Rod Slide Bearing	WCB + TFE	24	Piston Guide Ring	TFE
4	Adjusting Rod	Steel Alloy	25	Piston BUNA-N O-Ring Seal	BUNA-N
5	Adjusting Rod Nut	2H	26	Piston	Ductile Iron
6	Yoke	WCB	27	Center Cylinder Bar	Steel Alloy
7	Spring Housing	WCB	28	Center Cylinder Bar O-Ring Seal	BUNA-N
8	Yoke Slide Bearing	WCB + TFE	29	Stud	Steel Alloy
9	Spring Housing	Steel Alloy	30	Stud Nut	2H
10	Tension Rod	Steel Alloy	31	Sliding Bearing	WCB + PTFE
11	Spring Seat	WCB	32	Bolt	WCB
12	Yoke Slide Bearing Nut	2H	33	Body Cap	Ductile Iron
13	Pivot Slide Bearing	WCB + TFE	34	Bolt	WCB
14	Hydraulic Cylinder	WCB	35	Cover	Ductile Iron
15	Hydraulic Piston	WCB	36	Drive Shaft	Steel Alloy
16	Adapter	Ductile Iron	37	Roller	Steel Alloy
17	Cylinder BUNA-N O-Ring Seal	BUNA-N	38	Sliding Bearing	WCB + PTFE
18	Yoke Slide Bearing Nut	2H	39	Pin	Steel Alloy
19	Cylinder	WCB	40	Guide Block	Ductile Iron
20	Cylinder End Cap	Ductile Iron	41	Guide Block Nut	WCB
21	Cylinder End Cap Nut	2H	42	Spring Housing Cover Plate	WCB

\*Items listed in red are included in the repair kit.

### Operating Temperatures

Standard Temperature	-4°F to 176°F
Low Temperature	-40°F to 176°F
High Temperature	-4°F to 300°F

### Operating Pressure

Pneumatic	40 PSI to 100 PSI
Hydraulic	1450 PSI

THE BEST WAY TO AUTOMATE YOUR PROCESS

[www.max-airtechnology.com](http://www.max-airtechnology.com)

## TORQUE RANGE

### SPRING RETURN

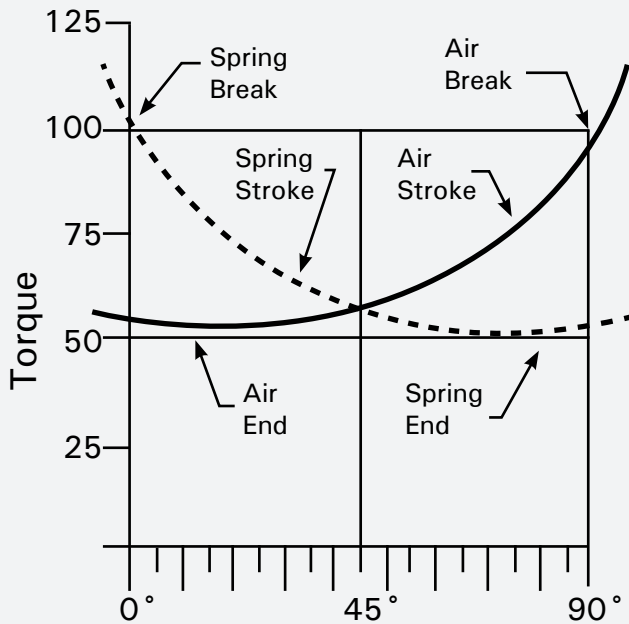

**DOUBLE ACTING  
SPRING RETURN**

### DOUBLE ACTING

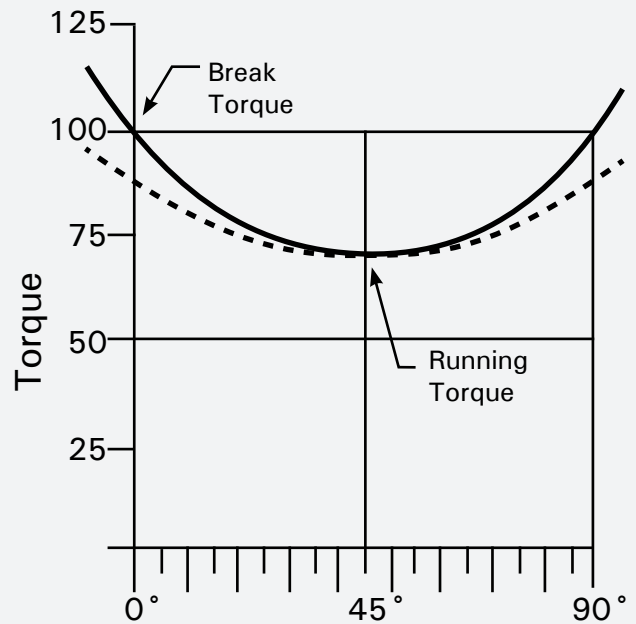

**7350 in-lbs to 2,003,810 in-lbs  
2700 in-lbs to 635,070 in-lbs**

## MECHANICAL OPERATION AND SIZING CONSIDERATIONS

The Scotch Yoke is a mechanism designed for converting linear force into rotation torque, usually at higher torque outputs than other conventional mechanical devices. The piston and spring mechanisms are directly coupled to a sliding yoke and pin device that provides for the transmission of power in a highly reliable and smooth operation. This type of mechanical device provides for the highest torque outputs to be generated at the beginning and

ending of the stroke cycle, and at decreasing speeds during the most critical point in the cycle; unseating and seating valves at their opening and closing phases. This design allows for the most desirable and efficient use of energy in large valve applications.

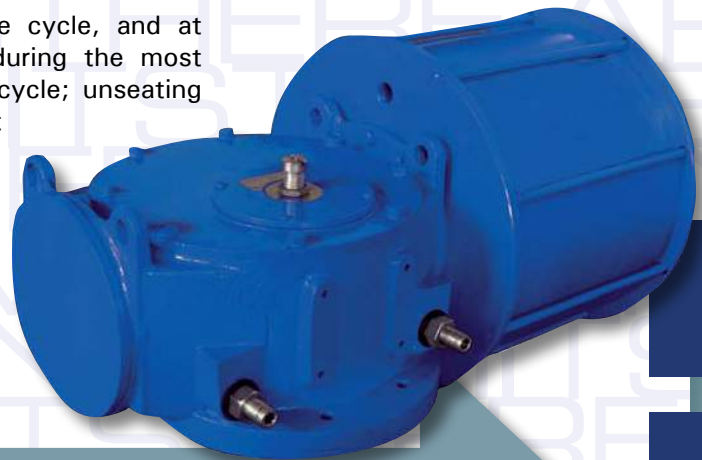

**When sizing scotch yoke actuators, it is important to take into consideration the following:**

- *Type of application desired (double acting or spring return service)*
- *Proper determination of the 'sizing torque'*
- *Understanding of the valve type and operation (ball, butterfly, plug, etc.)*
- *Knowledge of the related process media (oil, water, gas, powders, etc.)*
- *Review of minimum and maximum operational temperatures and pressures of the line media*
- *Consideration of environmental conditions which may affect the installation*
- *Finally, a safety and regulation review to ensure all aspects of the operation are compliant*

# DOUBLE ACTING TORQUE CHART

Units: in-lbs

Model No.	Weight (lbs.)	Max Drive Torque	43.5 PSI (3 Bar)		58.0 PSI (4 Bar)		72.5 PSI (5 Bar)		87 PSI (6 Bar)		101.5 PSI (7 Bar)	
			Start	Run	Start	Run	Start	Run	Start	Run	Start	Run
SY14-DA-20-F14	125		7,346	4,461	9,798	5,948	12,249	7,426	14,692	8,913	17,144	10,400
SY14-DA-25-F14	152	17,700	11,488	6,966	15,312	9,284	19,144	11,612	-	-	-	-
SY14-DA-30-F14	191		16,471	9,992	-	-	-	-	-	-	-	-
SY16-DA-25-F16	196		14,356	8,709	19,144	11,612	23,932	14,515	28,721	17,418	33,509	20,321
SY16-DA-30-F16	238	35,400	20,675	12,542	27,570	16,719	34,465	20,905	-	-	-	-
SY16-DA-35-F16	284		28,145	17,073	37,527	22,764	-	-	-	-	-	-
SY25-DA-35-F25	348		34,748	21,074	46,334	28,101	57,910	35,129	69,496	42,156	-	-
SY25-DA-40-F25	444	70,800	44,112	26,756	58,822	35,677	73,523	44,599	-	-	-	-
SY25-DA-45-F25	491		55,839	33,872	74,453	45,165	-	-	-	-	-	-
SY30-DA-45-F30	627		68,239	41,395	90,986	55,193	113,732	68,992	136,479	82,790	-	-
SY30-DA-50-F30	715	141,600	84,250	51,104	112,343	68,151	140,426	85,188	-	-	-	-
SY30-DA-55-F30	772		101,952	61,849	135,939	82,462	-	-	-	-	-	-
SY35-DA-55-F35	939		129,752	78,710	173,006	104,952	216,250	131,186	259,504	157,428	302,758	183,671
SY35-DA-60-F35	1019	283,200	154,419	93,676	205,895	124,902	257,362	156,127	308,838	187,362	-	-
SY35-DA-70-F35	1192		210,188	127,513	280,250	170,014	-	-	-	-	-	-
SY40-DA-60-F40	1399		-	-	-	-	312,520	189,592	375,033	227,517	437,537	265,434
SY40-DA-70-F40	1591	557,596	-	-	340,302	206,444	425,385	258,061	510,458	309,670	595,532	361,288
SY40-DA-80-F40	1852		333,355	267,956	444,476	357,269	555,597	446,591	-	-	-	-
SY48-DA-80-F48	2361		-	-	-	-	653,646	396,540	784,380	475,852	915,106	555,163
SY48-DA-90-F48	2937	1,106,340	-	-	661,815	401,497	827,262	501,891	992,718	602,240	1,158,174	702,617
SY48-DA-100-F48	3432		612,799	371,758	817,066	495,695	1,021,332	619,606	-	-	-	-
SY60-DA-80-F60	3707		-	-	-	-	-	-	1,058,913	642,405	1,235,397	749,473
SY60-DA-90-F60	4334		-	-	893,457	542,029	1,116,814	677,534	1,340,181	813,039	1,563,547	948,544
SY60-DA-100-F60	4862	2,212,685	827,271	501,873	1,103,034	669,170	1,378,788	836,458	1,654,550	1,003,755	1,930,304	1,171,043
SY60-DA-110-F60	5522		1,000,993	607,268	1,334,667	809,693	1,668,331	1,012,119	2,001,995	1,214,580	2,335,660	1,416,961

### 3 BAR (43.5 PSI) Air Supply Spring Return Torque Sheet

Units: in-lbs

Model No.	Air Supply Pressure	Max Drive Torque	Spring Start	Spring End	Air Start	Air End
SY14-SR3-20-F14	3 BAR (43.5 PSI)	17,700	4,523	2,717	4,629	2,815
SY14-SR3-25-F14	3 BAR (43.5 PSI)		6,983	4,478	7,001	4,496
SY14-SR3-30-F14	3 BAR (43.5 PSI)	35,400	9,550	5,965	10,568	6,992
SY16-SR3-25-F16	3 BAR (43.5 PSI)		9,665	5,346	8,975	4,682
SY16-SR3-30-F16	3 BAR (43.5 PSI)		12,692	7,895	12,780	7,983
SY16-SR3-35-F16	3 BAR (43.5 PSI)	70,800	16,781	10,860	17,286	11,356
SY25-SR3-35-F25	3 BAR (43.5 PSI)		19,905	12,807	20,764	13,869
SY25-SR3-40-F25	3 BAR (43.5 PSI)		26,517	16,772	27,340	16,843
SY25-SR3-45-F25	3 BAR (43.5 PSI)		35,049	22,428	33,403	20,782
SY30-SR3-45-F30	3 BAR (43.5 PSI)	141,600	42,360	25,570	42,669	25,880
SY30-SR3-50-F30	3 BAR (43.5 PSI)		53,494	31,287	52,963	30,756
SY30-SR3-55-F30	3 BAR (43.5 PSI)	283,200	60,778	38,492	63,451	41,165
SY35-SR3-55-F35	3 BAR (43.5 PSI)		81,250	47,794	81,958	48,502
SY35-SR3-60-F35	3 BAR (43.5 PSI)		97,500	56,450	97,969	56,910
SY35-SR3-70-F35	3 BAR (43.5 PSI)	557,596	127,884	78,834	131,345	82,294
SY35-SR3-60-F35	3 BAR (43.5 PSI)		116,219	71,815	115,688	71,284
SY35-SR3-70-F35	3 BAR (43.5 PSI)		144,789	90,915	164,305	110,431
SY40-SR3-80-F40	3 BAR (43.5 PSI)		189,636	120,954	212,400	143,718
SY48-SR3-80-F48	3 BAR (43.5 PSI)	1,106,340	235,598	144,984	247,201	156,579
SY48-SR3-90-F48	3 BAR (43.5 PSI)		299,545	184,335	312,024	196,814
SY48-SR3-100-F48	3 BAR (43.5 PSI)	2,212,685	405,267	257,530	355,269	207,524
SY60-SR3-80-F60	3 BAR (43.5 PSI)		325,708	201,841	316,848	192,991
SY60-SR3-90-F60	3 BAR (43.5 PSI)		417,030	246,423	423,659	253,061
SY60-SR3-100-F60	3 BAR (43.5 PSI)	698,129	561,120	338,639	488,623	266,151
SY60-SR3-110-F60	3 BAR (43.5 PSI)		698,129	435,607	565,395	302,864

### SPRING RETURN TORQUE CHART

# SPRING RETURN TORQUE CHART

## 4 BAR (58.0 PSI) Air Supply Spring Return Torque Sheet

Units: in-lbs

Model No.	Weight (lbs.)	Air Supply Pressure	Max Drive Torque	Spring Start	Spring End	Air Start	Air End
SY14-SR4-20-F14	257	4 BAR (58.0 PSI)	17,700	6,010	3,859	5,939	3,788
SY14-SR4-25-F14	343	4 BAR (58.0 PSI)		9,550	5,965	9,346	5,762
SY14-SR4-30-F14	400	4 BAR (58.0 PSI)		13,073	8,391	13,666	8,984
SY16-SR4-25-F16	405	4 BAR (58.0 PSI)	35,400	11,338	7,240	11,904	7,806
SY16-SR4-30-F16	460	4 BAR (58.0 PSI)		16,781	10,860	16,710	10,789
SY16-SR4-35-F16	590	4 BAR (58.0 PSI)		22,968	14,418	23,109	14,559
SY25-SR4-35-F25	695	4 BAR (58.0 PSI)	70,800	26,517	16,772	28,260	18,516
SY25-SR4-40-F25	781	4 BAR (58.0 PSI)		35,049	22,428	36,394	23,773
SY25-SR4-45-F25	849	4 BAR (58.0 PSI)		43,855	26,543	47,900	30,588
SY30-SR4-45-F30	1175	4 BAR (58.0 PSI)	141,600	56,016	33,810	57,185	34,978
SY30-SR4-50-F30	1340	4 BAR (58.0 PSI)		70,178	43,094	69,248	42,156
SY30-SR4-55-F30	1668	4 BAR (58.0 PSI)		82,976	51,547	84,383	52,954
SY35-SR4-55-F35	2193	4 BAR (58.0 PSI)	283,200	108,838	66,212	106,793	64,168
SY35-SR4-60-F35	2424	4 BAR (58.0 PSI)		127,884	78,834	127,061	78,002
SY35-SR4-70-F35	2882	4 BAR (58.0 PSI)		168,775	102,217	178,024	111,466
SY40-SR4-60-F40	2706	4 BAR (58.0 PSI)	557,596	144,789	90,915	159,101	105,218
SY40-SR4-70-F40	3124	4 BAR (58.0 PSI)		189,636	120,954	219,339	150,666
SY40-SR4-80-F40	4103	4 BAR (58.0 PSI)		265,655	166,014	278,453	178,812
SY48-SR4-80-F48	5148	4 BAR (58.0 PSI)	1,106,340	299,545	184,335	338,577	223,366
SY48-SR4-90-F48	6195	4 BAR (58.0 PSI)		405,267	257,530	404,276	256,548
SY48-SR4-100-F48	7436	4 BAR (58.0 PSI)		507,573	311,546	505,511	309,493
SY60-SR4-80-F60	6974	4 BAR (58.0 PSI)	2,212,685	417,030	246,423	459,513	288,906
SY60-SR4-90-F60	8180	4 BAR (58.0 PSI)		561,120	338,639	554,809	332,328
SY60-SR4-100-F60	9306	4 BAR (58.0 PSI)		698,129	435,607	667,426	404,895
SY60-SR4-110-F60	10868	4 BAR (58.0 PSI)		848,707	514,910	819,756	485,959

## 5 BAR (72.5 PSI) Air Supply Spring Return Torque Sheet

Units: in-lbs

Model No.	Air Supply Pressure	Max Drive Torque	Spring Start	Spring End	Air Start	Air End
SY14-SR5-20-F14	5 BAR (72.5 PSI)	17,700	6,983	4,478	7,762	5,257
SY14-SR5-25-F14	5 BAR (72.5 PSI)		11,904	7,213	11,922	7,240
SY14-SR5-30-F14	5 BAR (72.5 PSI)	35,400	16,639	10,674	16,887	10,931
SY16-SR5-25-F16	5 BAR (72.5 PSI)		13,745	8,948	14,975	10,178
SY16-SR5-30-F16	5 BAR (72.5 PSI)		21,428	12,878	21,578	13,028
SY16-SR5-35-F16	5 BAR (72.5 PSI)		28,269	18,454	28,455	18,640
SY25-SR5-35-F25	5 BAR (72.5 PSI)	70,800	35,049	22,428	33,863	21,242
SY25-SR5-40-F25	5 BAR (72.5 PSI)		43,855	26,543	46,989	29,668
SY25-SR5-45-F25	5 BAR (72.5 PSI)		55,990	32,978	60,079	37,067
SY30-SR5-45-F30	5 BAR (72.5 PSI)	141,600	70,178	43,094	69,850	43,563
SY30-SR5-50-F30	5 BAR (72.5 PSI)		82,976	51,547	88,879	57,441
SY30-SR5-55-F30	5 BAR (72.5 PSI)		101,129	62,770	107,147	68,788
SY35-SR5-55-F35	5 BAR (72.5 PSI)		127,884	78,834	137,426	88,366
SY35-SR5-60-F35	5 BAR (72.5 PSI)	283,200	160,951	95,163	162,208	96,420
SY35-SR5-70-F35	5 BAR (72.5 PSI)		211,214	124,875	225,429	139,090
SY40-SR5-60-F40	5 BAR (72.5 PSI)	557,596	189,636	120,954	191,566	122,884
SY40-SR5-70-F40	5 BAR (72.5 PSI)		265,655	166,014	259,362	159,721
SY40-SR5-80-F40	5 BAR (72.5 PSI)		313,538	191,875	363,722	242,059
SY48-SR5-80-F48	5 BAR (72.5 PSI)		405,267	257,530	396,115	248,379
SY48-SR5-90-F48	5 BAR (72.5 PSI)	1,106,340	507,573	311,546	515,724	319,698
SY48-SR5-100-F48	5 BAR (72.5 PSI)		616,030	377,201	644,122	405,294
SY60-SR5-80-F60	5 BAR (72.5 PSI)	2,212,685	561,120	338,639	543,781	321,300
SY60-SR5-90-F60	5 BAR (72.5 PSI)		698,129	435,607	681,216	418,685
SY60-SR5-100-F60	5 BAR (72.5 PSI)		848,707	514,910	863,877	530,080
SY60-SR5-110-F60	5 BAR (72.5 PSI)		994,550	635,165	1,033,175	673,781

## SPRING RETURN TORQUE CHART



# SPRING RETURN TORQUE CHART

## 6 BAR (87.0 PSI) Air Supply Spring Return Torque Sheet

Units: in-lbs

Model No.	Air Supply Pressure	Max Drive Torque	Spring Start	Spring End	Air Start	Air End
SY14-SR6-20-F14	6 BAR (87.0 PSI)	17,700	9,099	5,514	9,178	5,603
SY14-SR6-25-F14	6 BAR (87.0 PSI)		13,073	8,391	14,586	9,895
SY14-SR6-30-F14	6 BAR (87.0 PSI)	35,400	20,277	12,904	20,180	12,807
SY16-SR6-25-F16	6 BAR (87.0 PSI)		16,781	10,860	17,861	11,931
SY16-SR6-30-F16	6 BAR (87.0 PSI)		22,968	14,418	26,942	18,383
SY16-SR6-35-F16	6 BAR (87.0 PSI)		34,146	21,649	34,642	22,145
SY25-SR6-35-F25	6 BAR (87.0 PSI)	70,800	43,855	26,543	41,006	23,693
SY25-SR6-40-F25	6 BAR (87.0 PSI)		55,990	32,978	55,255	32,243
SY25-SR6-45-F25	6 BAR (87.0 PSI)		73,116	41,776	69,894	38,563
SY30-SR6-45-F30	6 BAR (87.0 PSI)	141,600	82,976	51,547	84,949	53,512
SY30-SR6-50-F30	6 BAR (87.0 PSI)		101,129	62,770	105,873	67,381
SY30-SR6-55-F30	6 BAR (87.0 PSI)	283,200	124,619	73,851	130,053	79,276
SY35-SR6-55-F35	6 BAR (87.0 PSI)		160,951	95,163	164,350	98,562
SY35-SR6-60-F35	6 BAR (87.0 PSI)		198,885	112,546	196,301	109,962
SY35-SR6-70-F35	6 BAR (87.0 PSI)	557,596	256,256	153,012	267,355	164,119
SY40-SR6-60-F40	6 BAR (87.0 PSI)		235,695	148,940	226,084	136,930
SY40-SR6-70-F40	6 BAR (87.0 PSI)		313,538	191,875	318,583	196,911
SY40-SR6-80-F40	6 BAR (87.0 PSI)		422,553	259,327	407,391	253,069
SY48-SR6-80-F48	6 BAR (87.0 PSI)	1,106,340	507,573	311,546	472,807	276,807
SY48-SR6-90-F48	6 BAR (87.0 PSI)		616,030	377,201	615,525	376,697
SY48-SR6-100-F48	6 BAR (87.0 PSI)		731,780	460,027	765,563	493,810
SY60-SR6-80-F60	6 BAR (87.0 PSI)	2,212,685	698,129	435,607	625,960	360,774
SY60-SR6-90-F60	6 BAR (87.0 PSI)		848,707	514,910	825,270	491,473
SY60-SR6-100-F60	6 BAR (87.0 PSI)		994,550	635,165	1,019,385	660,000
SY60-SR6-110-F60	6 BAR (87.0 PSI)		N/A	N/A	N/A	N/A

# DOUBLE ACTING DIMENSIONAL CHART

DA Dimensions

Units: inches

Model No.	Mounting Flange	L	L1	m1	m2	A	B	ØD	Air Inlet
SY14-DA-20-F14	F14	23.4	17.7	3.4	7.4	2.4	3.5	10.0	3/8"
SY14-DA-25-F14		23.4	17.7	3.4	8.4	2.4	3.5	12.0	1/2"
SY14-DA-30-F14		23.4	17.7	3.4	9.4	2.4	3.5	14.0	1/2"
SY16-DA-25-F16	F16	26.7	19.6	4.1	8.8	2.8	3.6	12.0	1/2"
SY16-DA-30-F16		26.7	19.6	4.1	9.7	2.8	3.6	14.0	1/2"
SY16-DA-35-F16		26.7	19.6	4.1	10.7	2.8	3.6	15.9	1/2"
SY25-DA-35-F25	F25	30.2	21.9	5.9	11.5	3.5	4.1	15.9	1/2"
SY25-DA-40-F25		30.2	21.9	5.9	12.5	3.5	4.1	17.9	3/4"
SY25-DA-45-F25		30.2	21.9	5.9	13.8	3.5	4.1	20.5	3/4"
SY30-DA-45-F30	F30	36.3	26.1	6.9	14.6	4.3	5.1	20.5	3/4"
SY30-DA-50-F30		36.3	26.1	6.9	15.6	4.3	5.1	22.4	3/4"
SY30-DA-55-F30		36.3	26.1	6.9	16.5	4.3	5.1	24.4	3/4"
SY35-DA-55-F35	F35	44.5	32.2	8.2	17.7	5.5	6.5	24.4	1"
SY35-DA-60-F35		44.5	32.2	8.2	17.7	5.5	6.5	26.4	1"
SY35-DA-70-F35		44.5	32.2	8.2	18.7	5.5	6.5	30.3	1"
SY40-DA-60-F40	F40	52.0	37.8	9.4	19.9	6.7	7.9	26.4	1"
SY40-DA-70-F40		52.0	37.8	9.4	21.9	6.7	7.9	30.3	1"
SY40-DA-80-F40		52.0	37.8	9.4	23.9	6.7	7.9	34.4	1-1/2"
SY48-DA-80-F48	F48	62.2	44.5	11.0	25.1	7.9	8.3	34.4	1-1/2"
SY48-DA-90-F48		62.2	44.5	11.0	27.1	7.9	8.3	38.4	2"
SY48-DA-100-F48		62.2	44.5	11.0	31.0	7.9	8.3	42.3	2"
SY60-DA-80-F60	F60	77.2	54.3	13.5	27.9	10.6	9.1	34.4	1-1/2"
SY60-DA-90-F60		77.2	54.3	13.5	29.8	10.6	9.1	38.4	2"
SY60-DA-100-F60		77.2	54.3	13.5	31.8	10.6	9.1	42.3	2"
SY60-DA-110-F60		77.2	54.3	13.5	33.8	10.6	9.1	46.3	2"

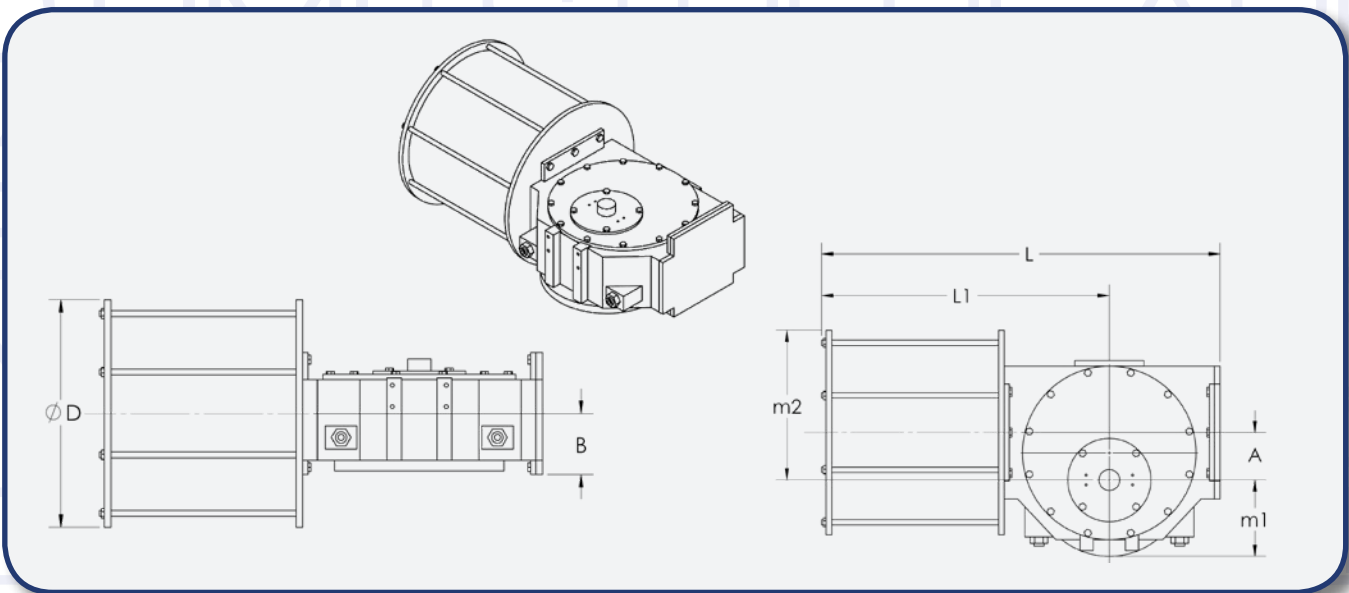

# SPRING RETURN DIMENSIONAL CHART

SR Dimensions

Units: inches

Model No.	Mounting Flange	L	L1	m1	m2	A	B	ØD	Air Inlet
SY14-SR*-20-F14	F14	43.5	17.7	3.4	7.4	2.4	3.5	10.0	3/8"
SY14-SR*-25-F14		43.5	17.7	3.4	8.4	2.4	3.5	12.0	1/2"
SY14-SR*-30-F14		44.3	17.7	3.4	9.4	2.4	3.5	14.0	1/2"
SY16-SR*-25-F16	F16	50.7	19.6	4.1	8.8	2.8	3.6	12.0	1/2"
SY16-SR*-30-F16		50.7	19.6	4.1	9.7	2.8	3.6	14.0	1/2"
SY16-SR*-35-F16		51.9	19.6	4.1	10.7	2.8	3.6	15.9	1/2"
SY25-SR*-35-F25	F25	62.0	21.9	5.9	11.5	3.5	4.1	15.9	1/2"
SY25-SR*-40-F25		62.0	21.9	5.9	12.5	3.5	4.1	17.9	3/4"
SY25-SR*-45-F25		65.9	21.9	5.9	13.8	3.5	4.1	20.5	3/4"
SY30-SR*-45-F30	F30	71.1	26.1	6.9	14.6	4.3	5.1	20.5	3/4"
SY30-SR*-50-F30		71.1	26.1	6.9	15.6	4.3	5.1	22.4	3/4"
SY30-SR*-55-F30		71.1	26.1	6.9	16.5	4.3	5.1	24.4	3/4"
SY35-SR*-55-F35	F35	78.9	32.2	8.2	17.7	5.5	6.5	24.4	1"
SY35-SR*-60-F35		78.9	32.2	8.2	17.7	5.5	6.5	26.4	1"
SY35-SR*-70-F35		78.9	32.2	8.2	18.7	5.5	6.5	30.3	1"
SY35-SR*-60-F35	F40	106.1	37.8	9.4	19.9	6.7	7.9	26.4	1"
SY35-SR*-70-F35		106.1	37.8	9.4	21.9	6.7	7.9	30.3	1"
SY40-SR*-80-F40		106.1	37.8	9.4	23.9	6.7	7.9	34.4	1-1/2"
SY48-SR*-80-F48	F48	133.7	44.5	11.0	25.1	7.9	8.3	34.4	1-1/2"
SY48-SR*-90-F48		133.7	44.5	11.0	27.1	7.9	8.3	38.4	2"
SY48-SR*-100-F48		141.1	44.5	11.0	31.0	7.9	8.3	42.3	2"
SY60-SR*-80-F60	F60	164.8	54.3	13.5	27.9	10.6	9.1	34.4	1-1/2"
SY60-SR*-90-F60		164.8	54.3	13.5	29.8	10.6	9.1	38.4	2"
SY60-SR*-100-F60		187.0	54.3	13.5	31.8	10.6	9.1	42.3	2"
SY60-SR*-110-F60		187.0	54.3	13.5	33.8	10.6	9.1	46.3	2"

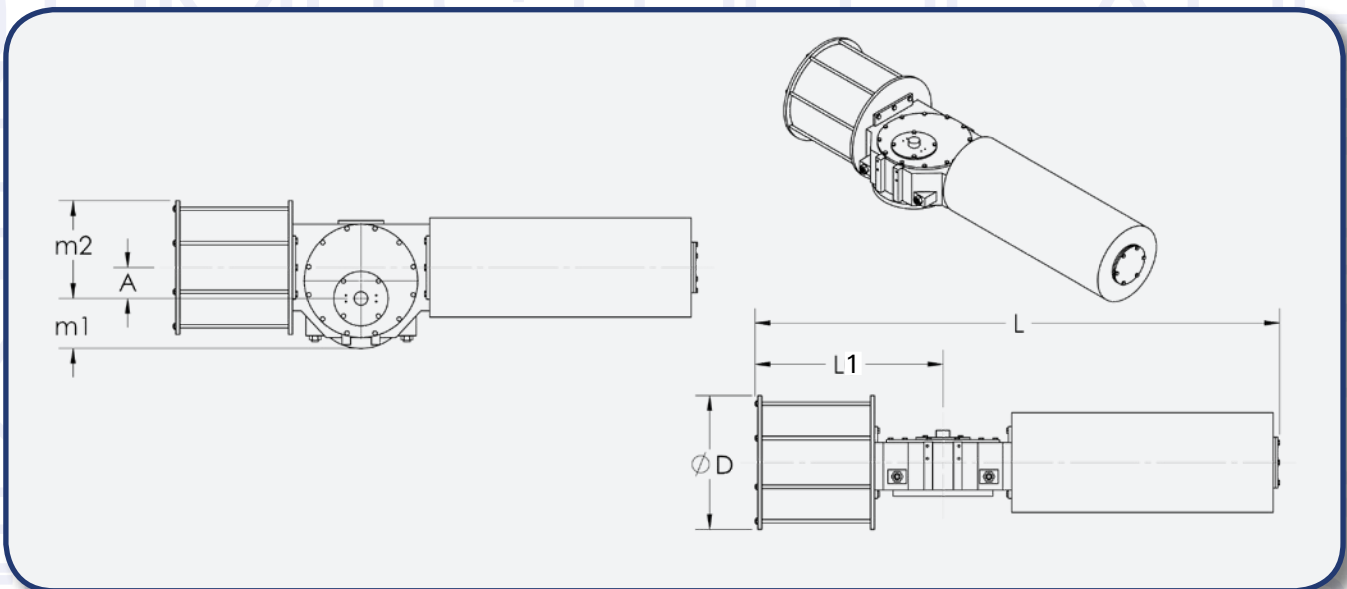

THE BEST WAY TO AUTOMATE YOUR PROCESS

[www.max-airtechnology.com](http://www.max-airtechnology.com)



# Max-Air TECHNOLOGY

The Best Way to Automate Your Process

Did you know that we provide the following services?

- 2D and 3D CAD Assembly Drawings
- Trained Technical Support Services
- On-site Commissioning Services
- Engineering System Design Services

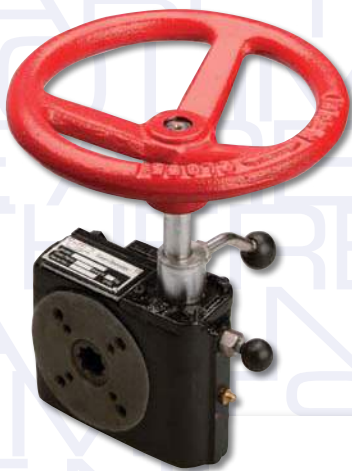
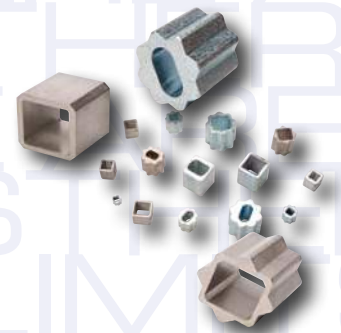

Your nearest Max-Air dealer can be found at:

