

rotork®

Controls

Introducing the next generation of intelligent valve control.

For over 50 years Rotork have used innovation for designing reliable, flexible and robust valve actuators and control systems. Continuing our ethos of evolving design, the next generation IQ multi-turn actuator is now available. Reliability standards have been set even higher, it is simpler to commission and use and is unrivalled in its ability to provide valve and process control operational data.

Outstanding reliability

Valve operation must be reliable. Rotork IQ actuators are designed to meet the toughest applications and engineered for a lifetime of uninterrupted service. Built on the drive train used for over 40 years, next generation IQ actuators feature numerous enhancements including advanced absolute position measurement, simplified control components, increased thrust base integrity; separable across all sizes, high immunity from spurious signals plus a dedicated "enable" input. In addition, casing material selection and coatings have been selected for improved corrosion protection.

Asset management

With a class leading dual stacked display, position, torque, status and configuration data is clear and immediate. In addition and unique to IQ, the valve, actuator and process data is available on screen or in the control room. Valve stroke force graphs, duty trend logs and valve and actuator manufacturing data can be extracted by the user and stored as the basis for planned maintenance and operational activities, process performance characteristics and comparison.

Commissioning and configuring next-generation IQ actuators is faster and simpler than ever. In addition to a new and intuitive user interface, entire operations can now be carried out in moments and datalogger data downloaded using the supplied Bluetooth® Setting Tool.



Redefining Flow Control



IQ Range

Intelligent Electric Actuator



rotork® Controls



Simple, secure commissioning and configuration

Ensuring correct configuration and keeping it secure is the bedrock of reliable operation.

All IQ actuators are set up non-intrusively using the IQ setting tool. Torque levels, position limits, control and indication functions can all be accessed using our intrinsically safe, wireless handheld setting tool. Compatible with existing infra red IQ setting tools, next generation IQ now can operate using its partner Bluetooth setting tool. Wireless connectivity allows easier use without direct-line of sight and over greater distances, however security has to match. This is achieved by the initial “pairing” of tool and actuator being carried out by a single infra-red transaction after which Bluetooth wireless connection automatically takes over. As before, configuration changes are password protected and the actuator is immune to connection by non-Rotork devices or programmes.

Next generation IQ actuators benefit from further advances in human interface design. In addition to a configurable, information-rich display, they offer a highly intuitive menu system for commissioning, updates and diagnostics.

With the latest version of the Rotork Insight2 software, you can further streamline actuator setup, by pre-defining complete sets of instructions and settings. Each collection of settings can be saved as a ‘mission’ and quickly applied to individual actuators via Bluetooth with the handheld setting tool.

IQ actuators can be interrogated and set even when mains power is not connected; the actuator can be configured and interrogated by using power from its indication battery.

Technological Advances

Position

Reliable valve position sensing is critical. Using the latest technology and after several years of testing, the patented Rotork IQ absolute encoder is contactless, has only 4 moving parts, can measure up to 8,000 output turns with a resolution of 7.5° and has redundancy and self checking. Unlike existing absolute encoder designs, this technological breakthrough increases position sensing reliability while providing zero-power position measurement.

Display

The dual stacked display allows large segment character position displays down to -50 °C while the matrix display provides detailed setting, status and diagnostic multi-lingual screens. Overall the display is 30% bigger, is backlit to provide excellent contrast even in the brightest light conditions and is protected by a toughened glass window. An optional protective clip-in cover is available where high UV levels or abrasive conditions are present.

Redefining Flow Control

IQ Range

Intelligent Electric Actuator

Torque

Next generation IQ utilises the piezo torque sensor developed and used successfully by Rotork for over 10 years. Now enhanced with on board, miniature amplification it is more reliable and better protected. Along with increased sensor support, increased reliability torque sensing over the life of the actuator has been achieved.

Control

Control elements such as main control and network interfaces cards like those used with Modbus or Profibus systems are connected internally using CANbus, reducing wiring and connections and increasing reliability; features demanded in the automotive industry where CANbus is used extensively.

Indication power

With the absolute encoder a battery is not required for position sensing and tracking. As all configuration and datalogger data is stored in non-volatile EEPROM memory, all settings are safe when no power is available. However, to maintain the display and ensure remote indication is kept updated should the valve be moved using the handwheel, an indication battery is included as standard. Reduced power consumption means the battery has a very long life – up to 5 years and should it become flat then nothing can be “lost”. The battery is low-cost and available from suppliers globally. In addition, the auxiliary power module option allows the user to connect a 24 V supply to the actuator should communication with network systems be required when main actuator power is switched off.

Optimised for preventative maintenance

All IQ actuators incorporate a sophisticated data logger, which can provide comprehensive data capture and analysis for planned maintenance and trouble-shooting issues with valves and processes. They capture:

- Valve torque profiles
- Operational starts profiles
- Operational trend logs
- Event log

In addition, asset management data regarding the actuator, gearbox (when fitted) and the valve is stored within the actuator and available for download. Specific asset management available are:

- Running time
- Average torque
- Starts
- Life statistics

With next-generation IQ actuators this data can be viewed in real time using the large dual stacked display. In addition, the data can be downloaded wirelessly with the Bluetooth Setting Tool or to a PC and analysed using the Rotork Insight2 software.

Safe manual operation

In case of an emergency, power outage or failure of the control network, IQ actuators can be operated by hand. A manual clutch and handwheel allow an operator to disengage the motor and operate the valve independently, without risk of damage.

Where the location requires it, the clutch can be padlocked into position to prevent accidental or unauthorised manual operation.

Manual movements of the valve are recorded and logged by the actuator. Position sensing in Rotork IQ actuators is highly reliable (power on or off) thanks to the unique robust and simple design of the absolute encoder.

Flexible network system connectivity

All IQ actuators are fully compatible with the Rotork Pakscan digital bus control system. This gives the advantage of a simple, twisted-pair data highway with inbuilt redundancy that maintains control even in case of cable or equipment failure.

Next generation IQ actuators are also wireless-ready with Pakscan Wireless control networks.

IQ actuators are also fully compatible with major open Fieldbus protocols including Profibus®, Foundation Fieldbus™, HART® and Modbus®.

Future-proofing

Next-generation IQ actuators have been designed with future advances in mind. In addition to highly configurable setup options they now feature flexible design technology.

Using the Rotork Insight2 software and handheld setting tool, it is also possible to apply updates to each actuator. This procedure is subject to 4 layers of security, with the option of disabling the Bluetooth communication for maximum security.

Next-generation advances

- New intuitive user interface.
 - Advanced dual stacked display with configurable datalogger functionality.
 - Toughened glass screen plus optional environmental shield.
 - Setting tool with secured Bluetooth connection.
 - High reliability, solid-state controls.
 - Reduced internal wiring and connections.
 - Simplified torque sensor.
 - Simple and robust absolute position sensor with high reliability and accuracy.
 - New thrust base rated to five times overload.
 - Separable gearbox/thrust base across the range.
 - Advanced Real-time status reporting.
-

rotork® Controls

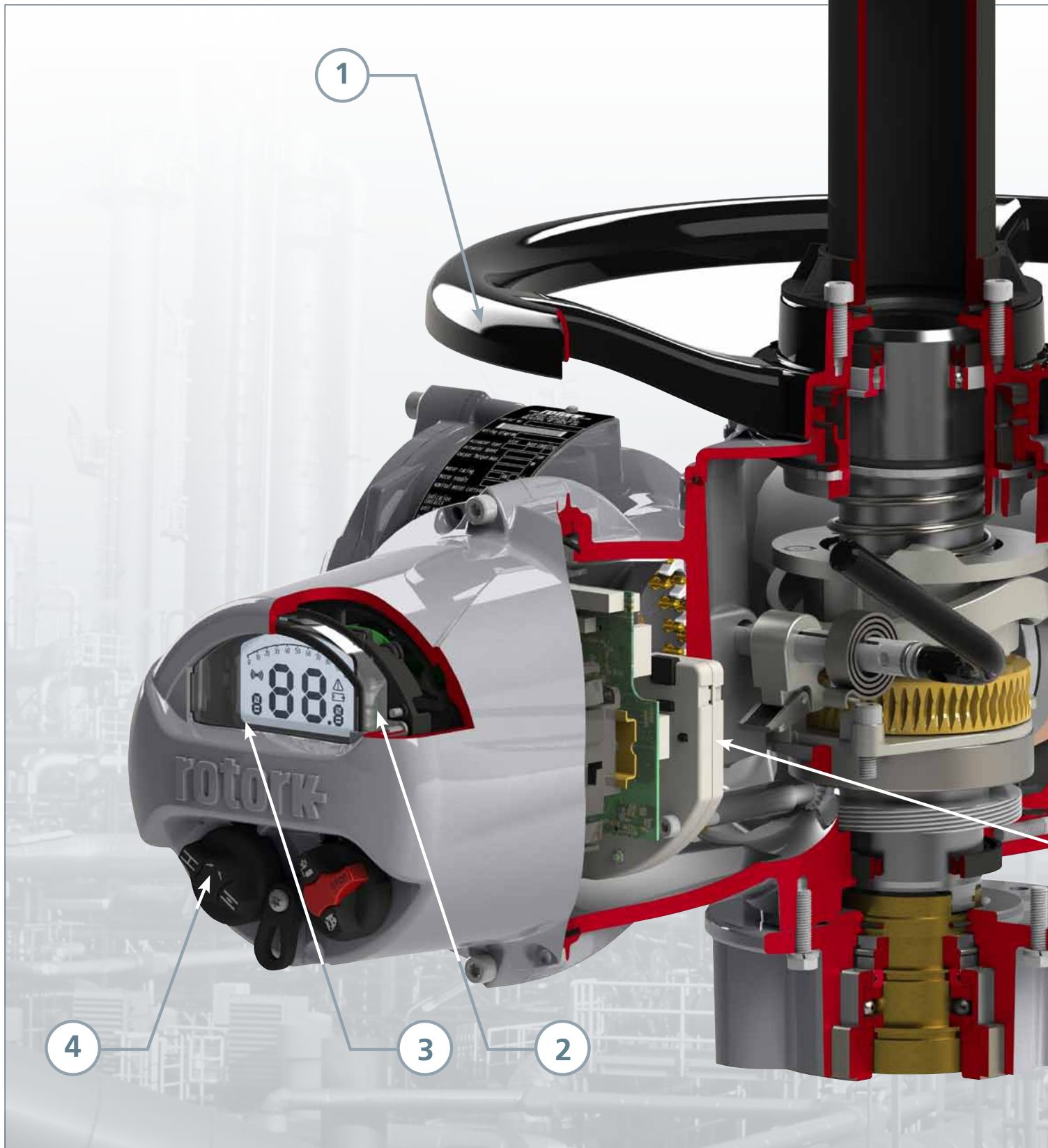

Redefining Flow Control



1 Hand operation

Direct drive handwheel (or geared handwheel on larger sizes) provides reliable emergency manual operation in the event of a power supply failure. Includes padlockable hand/auto clutch for safe operation even when the motor is running.

Note: power operation always has preference unless hand/auto lever is purposely locked into 'hand drive'. Lost motion 'hammerblow' effect is provided with both direct and independently geared handwheels.

2 Non-intrusive setting

All actuator settings and diagnostics can be made without removing any covers. With our wireless Setting Tool the actuator can be interrogated and updated, while remaining completely protected from the plant environment.

3 IQ3 Advanced display

All IQ3 models feature our next-generation, intuitive user interface for quick and easy commissioning and configuration. Their advanced screens provide flexible, at-a-glance views of plant valve status and remain functional even at very low temperatures.

4 Local controls

Local controls and padlockable Local/Stop/Remote selector switch operate internal switches, avoiding penetrating shafts which would have to be sealed to prevent moisture ingress.

5 Position control

The unique position sensor in Rotork IQ actuators provides a highly accurate and reliable system to report the precise position of the actuator.

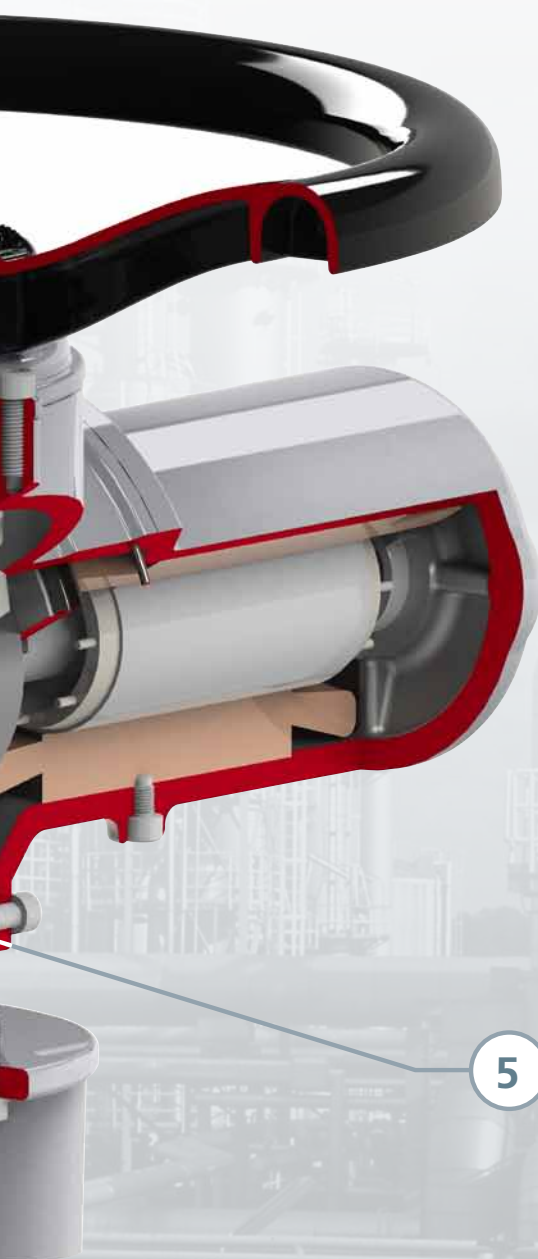

5

IQ3 Multi-turn actuators



Features include:

- Three-phase, direct current and single-phase variants
- Advanced, multilingual display for status and setup
- Detailed data logging
- Setting and data capture via Bluetooth® handheld tool
- InSight2 PC software for valve performance analysis
- Highly intuitive user interface
- Comprehensive control and flexibility.

IQ

IQ multi-turn electric actuators which can be used for isolation or regulating duties of up to 60 starts per hour. IQ actuators can be supplied as watertight or explosion-proof, watertight variants.

Direct torque output range from 34 Nm (25 lbf ft) to 3,000 Nm (2,200 lbf ft).

With the addition of second stage gearboxes, multi-turn output torque up to 43,000 Nm and quarter turn up to 1,000,000 Nm is available.

IQM

The modulating version of the IQ has a solid state reversing starter in place of the electromechanical contactors.

They feature fast-response remote control circuits for rapid control. To optimise positional control, the solid state starter also adds an electronic motor 'brake' feature.

The 'hammer-blow' drive - for shifting infrequently used valves - is not included in this model. IQM is suitable for up to 1,200 starts per hour.

IQML

Benefiting from all the features of the IQM actuator, the IQML has a linear output drive providing modulating thrust output of up to 150 kN.

IQS

IQS actuators are single phase versions of IQ actuators. Torque range from 65 Nm (48 lbf ft) to 450 Nm (332 lbf ft).

Special Designs

If you require an IQ actuator for duties that are not covered by our standard range, we are happy to discuss custom solutions.



IQ Range

Intelligent Electric Actuator

	Electrical Supply	Actuator Type	Duty Cycle	Torque Range*
IQ	3-phase	Multi-turn isolating/regulating duty	60 starts hour	14 - 3,000 Nm direct drive. When combined with a gearbox up to 43,000 Nm multi-turn or 1,000,000 Nm quarter-turn.
IQM/ML	3-phase	Multi-turn modulating duty	up to 1200 starts/hour S4 - 50% duty	12 - 550 Nm with linear output thrust range 5 - 100 Kn
IQS	Single-phase	Multi-turn isolating/regulating duty	60 starts/hour	25 - 450 Nm
IQT Pro	3-phase, Single-phase & Direct Current	Direct drive quarter-turn isolating/regulating duty	60 starts/hour	50 - 2,000 Nm
IQTM Pro	3-phase, Single-phase & Direct Current	Direct drive quarter-turn modulating duty	up to 1200 starts/hour S4 - 50% duty	50 - 2,000 Nm
IQTF Pro	3-phase, Single-phase & Direct Current	Direct drive slow speed full-turn	S2 - 20%, 60 starts/hour, at 75% of rated torque	50 - 2,000 Nm

* Actuator direct output. Higher torque ranges are available using gearbox combinations.

Supporting documents and software are available for download at www.rotork.com

PC Software	Insight2 (IQ), Insight (IQT Pro), PDA software: IQ Pocket Insight (IQT Pro) available for free download	PUB002-022	IQT electric motor performance data.
		PUB002-003	IQ Installation & Maintenance Instructions.
		PUB002-004	IQT Installation & Maintenance Instructions.
PUB002-001	IQ Range Catalogue	PUB002-015	Insight (IQT Pro) software.
PUB002-002	IQ Range Control and Monitoring	PUB095-002	Insight2 (IQ) software.
PUB002-018 /019/020/021	IQ electric motor performance data.	Dimensions	Dimensional drawings of all IQ and IQT Pro range actuators are available in PDF and DXF format in IQ/IQT range - Specifications.

A full listing of our worldwide sales and service network is available on our website.

www.rotork.com

UK

Rotork plc

tel +44 (0)1225 733200

fax +44 (0)1225 333467

email mail@rotork.com

USA

Rotork Controls Inc.

tel +1 (585) 247 2304

fax +1 (585) 247 2308

email info@rotork.com

Controls

Electric Actuators and Control Systems

Fluid Systems

Fluid Power Actuators and Control Systems

Gears

Gearboxes and Gear Operators

Instruments

Precision Control Instruments

Site Services

Projects, Services and Retrofit

As part of a process of on-going product development, Rotork reserves the right to amend and change specifications without prior notice. Published data may be subject to change. For the very latest version release, visit our website at www.rotork.com

The name Rotork is a registered trademark. Rotork recognises all registered trademarks. The Bluetooth[®] word mark and logos are registered trademarks owned by Bluetooth SIG, Inc. and any use of such marks by Rotork is under license. IrDA[®] is a trademark owned by the Infrared Data Association[®] and used with permission therefrom. Published and produced in the UK by Rotork Controls Limited. POWTG0412